



Request for Tender

MSAF Tender No.03/2023

for the

FABRICATION, SUPPLY & CONSTRUCTION OF MAKOGAI ISLAND LIGHTHOUSE

Date of Issue	27 January 2024
Closing Date	16 February 2024
Lodgment Address	MSAF Tender Box Level 4, Kadavu House, 414 Victoria Parade Suva, Fiji

REQUEST FOR TENDER

PROJECT:

**FABRICATION, SUPPLY & CONSTRUCTION OF MAKOGAI ISLAND
LIGHTHOUSE**

CONTENTS:

SECTION 1: FORM OF TENDER

Tender Details

Appendix 1 – Project Duration and Completion Details

Appendix 2 – Summary of Trades/Costs

Appendix 3 – Labour Rates Schedule

Appendix 4 – Plant Hire Rates

Appendix 5 – Additional Information Required from Tenderers

SECTION 2: CONDITIONS OF TENDER

SECTION 3: SPECIFICATION

General Structural Specification

SECTION 4: STRUCTURAL DRAWINGS

DEFINITIONS & INTERPRETATION

DEFINITIONS

“**AS**” means Australian Standard;

“**BS**” means British Standard;

“**DBGA**” means Department of Buildings & Government Architect, Ministry of Public Works, Transport & Meteorological Services;

“**inclement weather**” means continuous heavy rain or storm which may impede the progress of work

“**MSAF**” means Maritime Safety Authority of Fiji;

“**NZS**” means New Zealand Standard;

“**Standard Contract**” means Fiji Standard Form of Building Contract;

“**Tenderer**” may include Contractor and/or sub-contractor;

INTERPRETATION

Headings are for convenience only and do not affect interpretation. The following rules of interpretation apply unless the context requires otherwise:

- (a) The singular includes the plural and conversely.
- (b) A gender includes all genders.
- (c) Where a word or phrase is defined, its other grammatical forms have a corresponding meaning.
- (d) A reference to a person includes a body corporate, an unincorporated body or other entity and conversely.

SECTION 1: FORM OF TENDER

for the

fabrication, Supply and Construction of Makogai Island Lighthouse

FORM OF TENDER:	TENDER DETAILS
APPENDIX 1:	PROJECT DURATION AND COMPLETION DETAILS
APPENDIX 2:	SUMMARY OF TRADES/COSTS
APPENDIX 3:	LABOUR RATES SCHEDULE
APPENDIX 4:	PLANT HIRE RATES
APPENDIX 5:	ADDITIONAL INFORMATION REQUIRED FROM TENDERERS

FORM OF TENDER

(To be submitted with the Tender Submission)

Tender for:

FABRICATION, SUPPLY & CONSTRUCTION OF MAKOGAI ISLAND LIGHTHOUSE

Name of Tenderer.....

We, the undersigned hereby offer to execute and complete the whole works as stated on the said documents for the Fixed Lump Sum of:

(in words and numbers)

.....
.....
.....
.....

TOTAL TENDER PRICE (F\$VIP)

The above fixed Lump Sum must include VAT (15%) and with no provision for fluctuations in the cost of Labour and Materials.

As witness our hands this day Day of

Tenderer's Name:

Signature:

Office Stamp

Address:

Witness (Name in Capitals).....

Signature:

Address

Occupation

APPENDIX 1

PROJECT DURATION AND COMPLETION DETAILS

Tender for:

FABRICATION, SUPPLY & CONSTRUCTION OF MAKOGAI ISLAND Lighthouse

- a) Duration : 12 Calendar Weeks
- b) Defects Liability Period (Clause 15, 16 & 30) * : 12 months
- c) Retention : 10% at end of the Defects Liability Period
- d) Liquidated & Ascertained Damage (Clause 22) * : \$200.00 per day
- e) Public Liability Insurance (Clause 9 [1] a) * : \$500,000.00 (minimum)
- f) Insurance for the Works : Value of the total Contract Sum (minimum)
- g) Contractors All Risks : Approved Contract Sum plus 10%
- h) Workers Compensation Insurance : \$500,000.00
- i) Performance Bond : 30% of the project value

All prices to be in Fijian Dollars.

*** Clauses referred to above are contained in the Fiji Standard Form of Building Contract (Without quantities, Public Works Edition 1978).**

APPENDIX 2**SUMMARY OF TRADES/COSTS**

	Trade Description	Total Cost
A		
1.0	Preliminaries & General	
2.0	Excavation Works	
3.0	Construction of tower foundation - concrete slab	
4.0	Supply and install Aluminum Tower	
5.0	Supply and Installation of Aluminum Security mesh & ladder	
6.0	Painting	
	<i>Add on other job classification (trades) as necessary for this work.</i>	
	Sub Total	
	plus VAT (15%)	
	TOTAL TENDERED SUM	

Signature of Tenderer:.....

Tenderer's Stamp:

Date:

APPENDIX 3**LABOUR RATES SCHEDULE****Labour Rates Summary**

3.1 All Tenderers must submit their Labour and Plant rates that are applicable for this Project; this is a mandatory requirement. If any job/trade or plant / equipment classification is missing from below, the Tenderer is required to add into the spaces provided.

3.2 Labour Rates Summary

Item	Job Classification (Trades)	Hourly Rate (\$)
01	Supervisor	
02	Foreman	
03	Welder/Fabricator	
04	Plaster man	
05	Carpenter	
06	Painter	
07	Labourer	
08	<i>Add on other job classification (trades) as necessary for this work.</i>	
09		
10		
11		
12		
13		
14		
15		
16		
17		
18		
19		
20		
21		
22		
23		
24		

APPENDIX 4**PLANT HIRE RATES****Plant/Equipment Rates Summary**

- 4.1** All Tenderers are to submit their Plant/equipment rate that is applicable to this Project; this is a mandatory requirement. If any job or equipment classification is missing from below the Tenderer is required to add into the spaces provided.

item	Plant/Equipment Classification	Hourly Rate (\$)
01	Concrete Mixer	
02	Welding Plant	
03	Barge	
04	Rotary Hammer Drill	
05	Electrical Saw	
06	<i>Add on other job classification (trades) as necessary for this work.</i>	
07		
08		
09		
10		
11		
12		
13		
14		
15		
16		
17		
18		
19		
20		

APPENDIX 5

ADDITIONAL INFORMATION REQUIRED FROM ALL TENDERERS

Project:

**FABRICATION, SUPPLY & CONSTRUCTION OF MAKOGAI ISLAND
LIGHTHOUSE**

Contents

- A. Structure and Organization
- B. Financial Status
- C. Resources (Personnel/Plant/Equipment)
- D. Resources (Other)
- E. Relevant Experience

Notes to Tenderers

1. *Please fill-in clearly and neatly the spaces provided below.*
2. *Additional information may be attached at the back, if necessary.*
3. *Any queries regarding the filling of the Form of Tender are to be directed to MSAF.*

4. **A STRUCTURE AND ORGANIZATION**

1. Name of Company:

Certificate No. :

Tax Identification No. (T.I.N)

Contact Person:

Telephone Number:

Mobile:

E-mail Address:

2. Description of Company (for example, General Contractor)

3. Number of years' experience as a General Contractor in Fiji:

4. Please present organization chart showing the Tenderer/Company structure including the position of directors and key personnel.

Notes to Tenderers

1. Please fill-in clearly and neatly the spaces provided below.
2. Additional information may be attached at the back, if necessary.
3. Any queries regarding the filling of the Form of Tender are to be directed to MSAF.

B FINANCIAL STATUS

1. Annual value of construction work undertaken for each of the last two years.

2021	2022

2. Current commitments and value of work at hand since 2021 till to date.
-
-

3. Attach copies of the Tenderer's previous two years audited financial accounts.
4. Name and address of Banker where references can be obtained. Provide Bankers Report, financial status and overdraft facilities.

Notes to Tenderers

1. Please fill-in clearly and neatly the spaces provided below.
2. Additional information may be attached at the back, if necessary.
3. Any queries regarding the filling of the Form of Tender are to be directed to MSAF.

C RESOURCES: PERSONNEL/PLANT EQUIPMENT**1. Total Number of Staff in the Company:**

Technical:	Administrative:
------------	-----------------

2. Staff proposed to work on this Project:

Name:	Position :	No. of Years of experience in construction:

3. Main plant/equipment:

Considered by the Tenderer to be necessary for executing the Project and whether the plant is owned, or will be purchased or hired.

Notes to Tenderers

1. Please fill-in clearly and neatly the spaces provided below.
2. Additional information may be attached at the back, if necessary.
3. Any queries regarding the filling of the Form of Tender are to be directed to MSAF.

SECTION 2: CONDITIONS OF TENDER

for the

Fabrication, Supply & Construction of Makogai Island Lighthouse

Table of Contents

- 1.0 General Description of the Scope Works
- 2.0 Tenderer to Inform Himself
- 3.0 Detailed Description of the Work
- 4.0 Tenders
- 5.0 Qualification of Tenders
- 6.0 Tender Documents
- 7.0 Project Management
- 8.0 Progress Gantt Charts
- 9.0 Site Meetings
- 10.0 Inspection of Works
- 11.0 Fluctuation
- 12.0 Performance Bond
- 13.0 Period of Final Valuation
- 14.0 Delays / Time Extensions
- 15.0 Completion
- 16.0 Liquidated and Ascertained Damages
- 17.0 Claims and Payments
- 18.0 Retention
- 19.0 Defects Liability Period
- 20.0 Insurance
- 21.0 Duration of Work
- 22.0 Miscellaneous

1.0 General Description of the Scope of Works

The said works will include **FABRICATION, SUPPLY AND CONSTRUCTION OF MAKOGAI ISLAND LIGHTHOUSE.**

2.0 Tenderer to Inform Himself

- 2.1 The tenderer shall inspect and examine the structural drawings including the sites and surroundings, as to the form and nature of the project site and the cost implications of the provision of ships, accessories, electricity and water supply lines to the sites. This shall be satisfied before submitting the tender. The tenderer should also have a clear understanding of the quantities of the work and materials necessary, accommodation required, the availability of conditions and rates of pay of labour and shall inform himself of all risks, contingencies and other circumstances which may affect this tender.
- 2.2 Inspection of the site is to be carried out with MSAF and DBGA through arrangement with MSAF before submitting the tender.

3.0 Detailed Description of the Work

The extent of this Contract includes supply of all materials, labour, transportation and plant for the execution of the said project in accordance with this specification and drawing.

4.0 Tenders

Tenders are to be submitted on the enclosed FORM OF TENDER fully completed. This shall be submitted in a plain sealed envelope, marked:

Request for Tender – MSAF Tender 03/2023
“FABRICATION, SUPPLY AND CONSTRUCTION OF MAKOGAI ISLAND LIGHTHOUSE”

and addressed to:

**The Chairperson, Tender Committee
Maritime Safety Authority of Fiji
Level 4, Kadavu House, 414 Victoria Parade
Suva, Fiji**

Tenders are to be submitted no later than **Friday, 16 February 2024 at 1500 hours.** (Late tenders will not be accepted).

- 4.2 The lowest or any tender need not necessarily be accepted.
- 4.3 Maritime Safety Authority of Fiji reserves the right to REDUCE THE SCOPE OF WORKS to suit budgetary requirements. This will be decided prior to the contract signing.
- 4.4 All clarification/discrepancies on tender documents must be made and resolved before closing of tenders either in writing or verbally to MSAF.

5.0 Qualifications of Tenders

- 5.1 Any tenders not complying with any tender condition/requirement stated in the tender documents shall be considered non-conforming and will be disqualified.
- 5.2 Failure to submit the Tender Form fully completed will render the tender invalid.

6.0 Tender Documents

- 6.1 The documents for this Tender (inclusive in the contract) shall include the following:
- a) Tender Letter
 - b) Conditions of Tender
 - c) Form of Tender
 - d) Specification
 - e) Structural Drawing

If there are discrepancies or divergence between two (2) or more of the documents including a divergence between parts of anyone of them or between documents of the same description, the order of precedence shall be:-

- a) Structural Drawings
- b) Conditions of Tender
- c) Specification

7.0 Project Management

- 7.1 GENERAL: The Contractor shall be responsible for work executed under the contract including the work of the Sub-Contractor nominated or otherwise. The Contractor shall be responsible for the proper supervision of all works for which he is responsible and shall take all necessary measures to ensure quality control and workmanship.
- 7.2 Foreman: A competent Supervisor/Foreman shall be appointed and shall be in charge of the work for the duration of the Contract. Instructions given to him by MSAF shall be deemed to have been given to the Contractor. The foreman must be able to fully understand the drawings and instructions he has to administer.

8.0 Progress Gantt Charts

- 8.1 The tenderer shall within seven (7) days of the official acceptance of his tender, submit **three (3) copies of detailed work programme and order of work for approval**. The works include ordering of materials, fabrication, plant and equipment and elemental construction.
- 8.2 One (1) copy of the approved programme shall be kept on the site at all times and shall be marked regularly and clearly to indicate the progress throughout the construction period.

9.0 Site Meetings

- 9.1 MSAF with DBGA may arrange meetings with the contractor and sub-contractors (as necessary). Minutes of the meetings shall be recorded and circulated by MSAF.

10.0 Inspection of Works

10.1 MSAF/DBGGA shall at all times during construction have full access to all phases of the work for inspection.

11.0 Fluctuations

11.1 For the purpose of this Contract, the tender costs is to be the Fixed Lump Sum and will not be subject to Government regulated monetary fluctuations.

12.0 Performance Bond

12.1 The successful Contractor shall be expected to provide a Performance Bond equivalent of 30% of the Contract Sum. The Bond shall be released upon Practical Completion. Performance Bond is to be directly paid to MSAF by the successful bidder upon signing the contract.

13.0 Period of Final Inspection

13.1 The period of final valuation shall be twelve (12) months from the date of the practical completion certificate.

14.0 Delays / Time Extensions

14.1 Period of delay and extension of time shall be allowed for a maximum of one (1) month.

15.0 Completion

15.1 At completion, remove from the work site all plant, equipment, surplus materials, wastes and clean up the work site. Make good where necessary (checked and determined by MSAF/DBGGA) and facilitate testing of all hardware and equipment as necessary to ensure all are in working order before handover.

16.0 Liquidated and Ascertained Damages

16.1 This shall be in accordance with the Standard Contract and to be TWO HUNDRED DOLLARS (**\$200.00**) per day.

17.0 Claims and Payments

17.1 Progress payment claims and certified payments are to be made on the construction progress basis and in accordance with the Contract.

18.0 Retention

18.1 Retention shall be 10% of the contract sum and shall be paid out at the end of Defect Liability Period.

19.0 Defects Liability Period

19.1 The period shall be **12 months.**

20.0 Insurance

- 20.1 The Contractor is specifically required to insure against injury to persons and property.
- a) A policy specified under the Accident Compensation Act 2017.
 - b) A policy specified related to this building contract for its legal liability to the General Public to an amount not less than **five hundred thousand dollars (\$500,000.00)** (Refer to the Standard Contract).
 - c) Insurance against the works (refer to the Standard Contract). Minimum cover – Value of the Contract sum.

21.0 Duration of Works

- 21.1 This should refer as calendar weeks with 5 working days i.e., Monday to Friday with 45 hours of work per week. Any work beyond the aforementioned will be prerogative of the contractor.

22.0 Miscellaneous

- a) Tenderer to provide a Certificate of Ownership and individual shares in the company certified by a chartered accountant registered under the Fiji Institute of Accountants.
- b) Tender to provide the following documents with tender submission:
 - i. VAT registration Certificate
 - ii. Tax Compliance Certificate
 - iii. Company Certificate (Registrar of Company)
 - iv. FNPF Compliance Certificate
 - v. Compliance Letter (FNU Levy Payment)
 - vi. Experience in marine structural works
 - vii. Latest bank statements
 - viii. Latest financial statements
- c) Tenderer may contact the following officers for technical queries:

Manager Safety, Compliance & Response
Maritime Safety Authority of Fiji
Phone: +679 3315266 / 7706331

Or

Director of Buildings & Government Architect
Ministry of Infrastructure & Transport
Phone: +679 3384111

SECTION 3: SPECIFICATION

for the

Fabrication, Supply & Construction of Makogai Island Lighthouse

Notes:

- The Specifications are divided into sections as listed in the following index. Each section is complementary to the other Sections and all shall be constructed as mutually explanatory.
- Cross reference is given in the text to assist the Contractor. Cross referencing is not exhaustive and the absence of a cross reference shall not be taken as limiting the application of any clause.
- The Contractor shall notify the MSAF and DBGA in writing of any ambiguities or discrepancies in the specifications. The MSAF and DBGA will explain or adjust the specifications and will advise the Contractor in what manner the work is to be carried out.

General Structural Specifications

SECTION 1

1. GENERAL PRELIMINARIES

1.1. Project Description

- 1.1.1. The document is for the Fabrication, Supply and Construction of Makogai Island Lighthouse. Makogai Island is located north east of Ovalau Island and north Wakaya Island. The lighthouse is situated on a 271 metres peak at Latitude 17° 26'.97 South, Longitude 178° 57'.73 East. Refer to the locality diagram on Sheet 01 of the Structural Drawing and/or navigation chart extract.

1.2. Scope of Work

- 1.2.1. The work covered under this contract is the Construction of Concrete Base including Fabrication, Supply and Installation/Rigging of one (1) Aluminium Tower as per the structural drawing.

1.3. The Site

- 1.3.1. The location of the works in this contract and adjacent areas is shown on the attached drawings. The Contractor shall ensure that during the construction works there is minimal disturbance to marine/aquatic fauna in the area.

1.4. Access to Site

Access to Makogai Island is via ship. The site can also be accessed by boat from Levuka wharf, Ovalau. Distance from Levuka to Nasau village, Makogai is approximately 15 nautical miles. Helicopter may be used for fast and easy access for site visits and transportation of materials. The contractor is to obtain permission from MSAF to access the site.

1.5. Non-Interference with Local Operation

- 1.5.1. The contractor is required to liaise closely with relevant authorities through MSAF to ensure minimum disruption to the local operations (fishing boats, tourist boats, and passage boats) is achieved.

1.6. Security

- 1.6.1. The Contractor shall provide at all times such suitable and reliable security as maybe required to protect the works and to ensure the safety of personnel working in the project site. The Contractor will be entirely responsible for the security of his plant and materials and MSAF accepts no liability whatsoever for any loss or damage thereto.

1.7. Contractor's Superintendent

- 1.7.1. In accordance with the General Conditions of Contract, before commencement of any work on site the Contractor shall inform MSAF and DBGA in writing of his proposed arrangements for supervising the works and obtain MSAF and DBGA's approval thereto.

1.8. Existing Services

- 1.8.1. The Contractor shall prior to the commencement of work on site enquire of the relevant services within the project area, which do not form part of the Contract. The Contractor shall be responsible for taking all proper and reasonable precaution to protect these existing services and utilities from damage and shall make good any damage caused as a result of his own activities or his sub-contractor at his own cost.

1.9. Water, Electricity and Telephone

- 1.9.1. The Contractor shall make his own arrangements for all temporary electrical, water and telephone services required for the execution of the works and shall pay all costs incurred.

1.10. Stand-Down

- 1.10.1. The Contractor may allow for disruption to his programme in carrying out the works due to circumstances beyond his control.

1.11. Construction Programme

- 1.11.1. The Contractor shall prepare a detailed Construction Programme as required by the Contract. The Programme shall be in the form of a detailed gantt chart with interlinked activities and shall update and improve the programme submitted with the Contractor's Tender. Critical dates determined shall clearly be shown.
- 1.11.2. At the end of each month the Contractor shall furnish to MSAF and DBGA the following information in writing:
- a. The actual starting dates of all activities started during the month.
 - b. The actual dates of completion of activities completed during the month.
 - c. The current status of all work underway at the time of the report.
 - d. The reasons for any discrepancy between the Construction Programme and the progress as achieved under Sections (a) and (c) above, together with the Contractor's proposals for ensuring that all key and critical dates are achieved.
- 1.11.3. The Contractor shall fourteen (14) days prior to making major revisions in the Construction Programme advise MSAF and DBGA of such revisions. Any such revision shall be subject to MSAF and DBGA's approval.
- 1.11.4. MSAF and DBGA reserves the right to review the progress of the works from time to time and the Contractor shall assist with such reviews. MSAF and DBGA reserves the right to instruct the Contractor to modify and up-date the Construction Programme at any time during the progress of the Contract to ensure completion by the due dates and any such revisions shall be carried out at the Contractor's own cost but shall not relieve him of the responsibility for the sufficiency thereof. If any event occurs which delays the Contractor in his execution of any part of the works, it is the Contractor's responsibility to revise the programme in order to minimise the effect of any such delays.

1.12. Method of Work Statement

- 1.12.1 The Contractor shall prepare and submit for approval by MSAF and DBGA a method statement indicating how the Contractor proposes to carry out the works. The statement shall include:
- a. a list of equipment proposed to be used;
 - b. a list of professional staff;
 - c. detailed description of the construction method and sequence, including setting out, survey and quality control methods;
 - d. allowance made for difficulties in piling due to sea conditions, inclement weather, access restrictions, operation restrictions and other such factors;
 - e. reference to the construction programme and temporary works as required;
 - f. a detailed site preparation and method for the disposal of the unwanted material;
- 1.12.2 approval by MSAF and DBGA of the method statement shall not relieve the Contractor of any of his responsibilities to complete the work in accordance with the requirements of the Contract.

1.13. Permits, Certificates and other Consents

- 1.13.1. The Contractor shall obtain necessary permits, certificates and other like consents from Government and Local Authorities and shall submit all such permits to MSAF and DBGA.

1.14. Contractor's Works and Establishment Areas

- 1.14.1. The Contractor is responsible for making all arrangements and meeting all costs of his area, sheds, offices, stores and the storage of plant and materials within the establishment areas and within the area of works.
- 1.14.2. The Contractor shall at all times maintain his establishment area, office amenities, etc., in a clean and tidy condition.

1.15. Use of the Site

- 1.15.1. The Contractor shall not use any portion of the Site for any purpose not directly connected with the Works unless written permission from MSAF is first obtained.
- 1.15.2. The site in its entirety shall be deemed as private property and the Contractor shall keep out all trespassers and all persons lacking authorization by MSAF.
- 1.15.3. The Contractor shall confine his construction operations within the site, or such other areas as maybe negotiated and provided by MSAF and shall instruct his employees not to trespass.
- 1.15.4. Subject to any unavoidable disturbance, which maybe necessitated by the execution of the Contract, the Contractor shall not interfere with any environment sensitive areas, endangered species, areas of conservation fishing or other rights which may exist on or near the Site.
- 1.15.5. The Contractor shall not erect or allow to erect an advertisement in any form on the Site or on adjoining grounds without the written approval of MSAF.

- 1.15.6. The Contractor shall not set up or cause or allow to be set up on the site any business or retail establishment of any sort without the approval of MSAF.
- 1.15.7. The Contractor shall not establish on any portion of the site any living accommodation for his staff, employees, or sub-contractors without the written approval of MSAF.

1.16. Confidential Information

- 1.16.1. All plans, drawings and specifications and the subject matter contained therein remain the property of MSAF, and all other information given to or obtained by the Contractor in connection with the Work shall be held in confidence by the Contractor and shall not be used by the Contractor for any purpose other than for the performance of the Work or as authorised in writing by MSAF.

1.17. Records

- 1.17.1. Within one (1) week of commencing work on the Site, the Contractor shall furnish to MSAF and DBGA a fully detailed record of all plant and personnel employed on the Works, and additions or reductions shall thereafter be notified weekly within two (2) working days of the end of the weekly period.
- 1.17.2. The record shall differentiate between plant owned by the Contractor and that which is hired. In the case of hired plant, the record shall state from whom the plant has been hired, size, capacity, output and power rating of all plant shall be stated in the return.
- 1.17.3. The labour record shall show by trades the number of men employed, rates of pay, the work upon which they are engaged, and shall include employees of all subcontractors.
- 1.17.4. The Contractor shall, upon request, also supply to MSAF and DBGA any other records relating to work under the Contract which MSAF and DBGA may reasonably require.
- 1.17.5. The Contractor shall not destroy any of his records, timesheets, vouchers and the like on labour, constructional plant, materials and things before the end of the Contract and such records shall be available at any time for inspection by MSAF and DBGA and/or by a competent Authority for compliance with the requirements of the Contract and of the local laws and regulations and in order to enable investigation by MSAF and DBGA of any claim by the Contractor.

1.18. Publicity

- 1.18.1. The contractor shall not make media releases or publish or disclose anything pertaining to the works under this Contract, without obtaining the written approval of MSAF.
- 1.18.2. Except for the purposes specified in clause 1.19.1, the taking of photographs on the Site by, or on behalf of the Contractor or his sub-contractors shall not be allowed unless prior consent in writing has been obtained from MSAF. Should such consent be given one (1) copy of each photograph must be submitted to MSAF for its retention as soon as available at no cost to MSAF.

1.19. Photography

- 1.19.1. Prior to the commencement of the Works, the Contractor shall provide in duplicate photographic record of each site and any adjacent offshore areas, identified disposal site, structures, roads, fields and crops and at his expense shall supply progress photographs 150mm by 100mm in size (including digital copies) at monthly intervals. All photographs shall be annotated with the date and location.

1.20. Day work

- 1.20.1 Further to the Conditions of Contract, the Contractor may be required to perform additional works not defined elsewhere in the Contract by Day work.

- 1.20.2 All labour, plant and materials used on Day work shall be as agreed in writing by MSAF and DBGA prior to the commencement of the work. Three (3) quotations for the supply of materials or externally hired plant shall be obtained by the Contractor unless otherwise agreed by MSAF and DBGA.

- 1.20.3 Changes in resources employed on any items of Day work shall only be made with the written permission of MSAF and DBGA.

- 1.20.4 Day work shall be performed in accordance with the following provisions:-

a. Labour

- All Day work shall be carried out during the Contractor's normal working hours or as otherwise notified to MSAF and DBGA and no increase in Day work rates shall apply to any overtime, unless such overtime is outside the Contractor's normal working hours and the Contractor has been ordered in writing by MSAF and DBGA to perform work by Day work outside his normal working hours.

b. Material

- Materials required for Day work shall be supplied by the Contractor, unless otherwise directed by MSAF and DBGA.

-

c. Hire of Plant and Equipment

- The Contractor shall make reasonably available for Day work any item of plant or equipment normally employed on the work site. If such plant is committed on other work under the Contract, externally hired plant may be utilised.

- Payment of Day work shall be made in accordance with following provisions:-

i. Generally

- Where plant or labour are employed on Day work the Contractor shall, not later than noon on the next working day after such plant or labour is utilised, deliver to MSAF or

its authorized representative, duplicate copies of daily time sheets recording the amount of plant and labour so utilised for verification.

- After verification, MSAF will sign and return one (1) copy of each time sheet, either approved or modified, acknowledging the supply of plant or labour. The Contractor shall forward a copy of this countersigned sheet with his claim for payment which claim shall be made within twenty eight (28) days of the work being completed.
- Operations of plant which has been ordered to standby (and being paid under the relevant items in the Bill of Quantities) shall be paid for under the Schedule of Rates provided that they too are standing by and cannot be engaged on other work.

ii. Labour

- The Contractor's labour rates shall be deemed to cover all costs arising from the employment of labour including higher duties and mixed functions, overtime loading, night work, meals and meal money, holidays and annual leave, absence through sickness, shift work and overtime by shift works, food and accommodation allowances, walking and travelling time, travelling allowances and fares, tool allowances and special provisions.
- The rates shall be deemed to allow for all other labour-connected costs and for his remuneration in executing Day work under the Contract, including site supervision and administrative staff (MSAF and DBGA, engineers, foremen surveyors, draftsmen, time-keepers and clerks etc.), bonus or other additional emoluments, provision and maintenance of all hand tools and equipment, lamps, protective clothing and similar equipment, income tax, all insurances, inclement weather, cost of camps and cookhouse personnel, head office chargers and profit as applicable. The hours paid for will be those actually worked.

1.21 Meeting

- 1.21.1 The Contractor shall make regular site meeting with MSAF and DBGA to discuss the progress of the Contract. Site meetings shall be held once every month and additional meetings may be called by MSAF and DBGA when required.
- 1.21.2 MSAF and DBGA or their representatives would chair the meeting and shall take and distribute the minutes of such meetings. The minutes of the meeting shall be endorsed by all parties.

1.22 Inspection

- 1.22.1 The Contractor shall be required:
- To furnish, on the request of MSAF and DBGA or their authorized representative, any Government official, or authorized representative, the use of such boats, boatmen, and labourers reasonably necessary in inspecting and supervising the work; and
 - To furnish, on the request of MSAF and DBGA or their authorised representative, suitable transportation from all points on shore designated by MSAF and DBGA, to

and from the various pieces of plant, and to and from the disposal site for the purposes of inspecting and supervising the work.

- 1.22.2 Should the Contractor refuse, neglect or delay compliance with these requirements, the specific facilities maybe furnished and maintained by MSAF and DBGA, and the cost thereof will be deducted from any amounts due or to become due to the Contractor.

1.23 Reasonable Satisfaction

- 1.23.1 No expression of MSAF and DBGA's reasonable satisfaction or approval shall be deemed to be an acceptance of the defective materials or workmanship not complying with the terms of this Contract nor as authority for any variation except where such variation is authorized as provided in this contract in writing by MSAF and DBGA.

1.24 Demolition and Surplus Materials

- 1.24.1 All surplus materials removed from demolition and excavation work shall remain the property of the Owner, unless otherwise agreed. Contractor to allow for removal of surplus materials off the site, within a distance of 10Km from the site, subject to consultation with MSAF.

1.25 Delays

- 1.25.1 DELAY OF WORKPLAN BY INCLEMENT WEATHER
- a) Only those elements indicated in the workplan of work as being able to be affected by inclement weather will be considered when claims for extension of times are presented.
 - b) The claim must be backed by a certificate from the Fiji Meteorological Office indicating continuous inclement weather.
 - c) Only delays occurring in the work week from Monday to Friday and during normal working hours will be considered. Any work done during the Saturday & Sunday is the prerogative of the contractor.
 - d) The claim must be supported by the clerk of Works weekly reports.
- 1.25.2 Delays due to unavailability/delivery of materials will be considered if procedures outlined in Clause 20 have been adhered to.

SECTION 2

2 SITE SETTING OUT

2.21 General

- 2.21.1 The preliminary and general and Special Clauses of this Specification shall be read in conjunction with and shall form part of this Section.
- 2.21.2 All earthworks: To AS 3798.

2.22 Interpretation

- 2.22.1 **Bad ground:** Ground unsuitable for the purposes of the works, including fill liable to subsidence, ground containing cavities, faults or fissures, ground contaminated by harmful substances and ground which is or becomes soft, wet or unstable.
- 2.22.2 **Rock:** Monolithic material with a volume greater than 0.5 m³ which cannot be removed until broken up. The Contractor shall be deemed to have allowed for the cost of performing the required excavations in whatever material may be encountered, and no extra payment shall be paid for excavation in rock.
- 2.22.3 **Subgrade:** The trimmed or prepared portion of the formation on which the pavement or slab is constructed. Generally taken to relate to the upper line of the formation.
- 2.22.4 **Zone of influence:** A foundation zone bounded by planes extending downward and outward from the bottom edge of a footing, slab or pavement and defining the extent of foundation material having influence on the stability or support of the footings, slab or pavement.
- 2.22.5 **Rock or Bad Ground - Hold Point** - If rock or bad ground is encountered, advise the Superintendent immediately. Do not carry out any further work in the affected area until and unless instructed to do so by the Superintendent.

2.23 Site Clearing

- 2.23.1 Limit clearing to areas of cut and fill and areas to be occupied by works, such as structures paving, excavation, regrading, and landscape work or to other designated areas to be cleared.
- 2.23.2 Clearing operations, remove everything on or above the site surface, including rubbish, scrap, grass, vegetable matter and organic debris, scrub, trees, timber, stumps, boulders and rubble. Remove grassed soil to a depth just sufficient to include the root zone.

2.24 Setting Out

- 2.24.1 SCOPE
 - a) The work shall include setting out as shown in locality plan; excavation, backfilling, supply and install the light tower
- 2.24.2 EXCAVATION
 - a) The scope of excavation work shall include trenches for the tower foundation
 - b) Provide shoring, bracing and timbering if required.
 - c) Pump out if necessary to keep excavation clear of water.
- 2.24.3 BACKFILLING

2.24.4 RESTORATION OF SURFACES

The Contractor shall be responsible for the restoration of all ground disturbed as a result of construction works and any road paving, removed or damaged as a result of this contract. Any roads, paths, etc. so affected shall be restored with materials of the same nature and of equal quality to those contained in the original pavements, and to the same standards of construction and the same depth so as to produce at the end of the maintenance period a finished surface at least equal in all respects to that existing before the commencement of the works comprising this contract.

2.24.5 PRECAUTIONS AND SAFEGUARDS

- a) Where work is carried out in the roadway or footpath the Contractor shall provide all necessary watching, lighting, barriers and pedestrians crossings to ensure the safety of his workmen and the public.
- b) The Contractor shall carry out the work in a careful, secure, safe and tidy manner and take all precautions against accidents or damage, whether arising from bad workmanship, breakage of machinery or plant, inefficient timbering, flooding or any other cause whatsoever.

2.24.6 DISPOSAL OF SURPLUS

All surplus material and rubbish connected with this section of the work shall be removed from the site or disposal of as directed by MSAF/DBGA.

2.24.7 AUSTRALIAN STANDARDS

- Earthworks: To AS 3798.
- Site classification: To AS 2870 and BCA 3.2.4.
- Demolition: To AS 2601.

SECTION 3

3 EXCAVATIONS

3.21 Extent of Work

- 3.21.1 The work specified in this part comprises: excavations for the tower foundation.

3.22 Setting Out

- 3.22.1 The setting out of the work shall be carried out as per the structural drawings provided. Confirmation shall be made with the client on the said location before construction.
- 3.22.2 The setting out of the work must be approved by the Client on site.

3.23 Excavations Generally

- 3.23.1 Suspend all earthworks if directed or when unsatisfactory work would result, due to inclement, weather saturation of materials by seepage flows, or other condition. Recommence when materials are no longer affected.
- 3.23.2 Keep works free of water and protect by construction of necessary open drains. Maintain until no longer required.
- 3.23.3 Provide working space in excavation as required. If timbering is not used, batter excavations at angle of repose of subject materials.
- 3.23.4 Form external banks to grades as shown on drawings. At transitions to adjacent surfaces grade to minimum 1m radius.
- 3.23.5 Approval of all excavations to be obtained prior to further work.
- 3.23.6 Obtain written instructions before excavations below contract depth and levels.
- 3.23.7 All additional excavations shall be at Bill or Schedule rates.

3.24 Disturbed Ground

- 3.24.1 The Contractor shall make good to all ground disturbed as a result of construction works, outside the bounds to ensure that natural levels are maintained and finished to match surrounding areas.

3.25 Timbering for Excavations

- 3.25.1 Work to proceed in a careful safe way, with all due precautions being taken against accidents.
- 3.25.2 Contractor to erect shoring, metal casing, timbering etc., of sufficient strength and quality to prevent materials slipping or falling or being shaken from the side of the excavations.
- 3.25.3 If in the opinion of MSAF/DBGA, sufficient or proper support had not been provided at any point, he may order additional support to be supplied and fixed at the Contractor's expense. Such action of MSAF/DBGA will not release the Contractor of any responsibility for the sufficiency of these, or any other supports, care must be taken to prevent voids forming outside the sheeting. Should voids occur, they shall be backfilled with consolidated materials to MSAF/DBGA's satisfaction.
- 3.25.4 No excavations by machine is allowed within 1.0m of any existing underground services without prior approval of the MSAF/DBGA.
- 3.25.5 All shoring and timber to be struck and withdrawn as the work proceeds, except where unrecoverable metal casings are used and where written direction of MSAF/DBGA is received to the contrary.

3.26 Foundation Inspection

- 3.26.1 When excavation for the footings has been completed to the required bearing specified on the drawings, the Contractor shall notify and provide assistance to allow MSAF/DBGA to inspect each hole and trench.

3.27 Backfilling

- 3.27.1 No backfilling around footings or under slabs to be done without prior approval of MSAF/DBGA. Backfilling shall not exceed 150mm thick layers, each solidly compacted to a minimum 100% of maximum dry density.

Backfilling to be continuous under all launchings, set downs and the like. Make due allowance for thickness of fill of a tolerance of 0mm - 12mm.

- 3.27.2 Prepare the sub-grade under concrete floor slabs to the required levels to suit finished floor levels to a tolerance of 0mm-12mm. Preparation to be continuous under all launchings, set downs and the like.

3.28 Foundation and Piers

- 3.28.1 The depths for foundation piers shown on the drawings are for tendering purposed only and the work actually done will be measured on completion, and priced at bill rates or scheduled rates.
- 3.28.2 Clean out pier holes and remove all loose materials and consolidate bottoms to approval of MSAF/DBGGA.

3.29 Surplus Material

- 3.29.1 All surplus excavated material shall remain the property of MSAF.
- 3.29.2 Stockpile surplus topsoil separately from soapstone etc. to area near Works as directed by MSAF/DBGGA at site.

3.30 Waterproofing

- 3.30.1 Under concrete floor and slabs lay a continuous membrane of polythene vapour barrier (min 0.8mm thick) lapped 150mm at joints and turned up full depth at edges. Seal joints and any projections through polythene with recommended pressure sensitive tape all to the approval of MSAF/DBGGA.
- 3.30.2 In addition, the outer vertical surfaces of concrete foundations and concrete block walls below natural ground level shall be waterproof with an approved bituminous sealer, or equal applied manufacturer's recommendation all to the approval of MSAF/DBGGA.
- 3.30.3 NOTE: All concrete slabs and shallow foundations shall be set on the polythene vapour barrier which shall be set on 50mm minimum sand blinding on 100mm minimum complicated hard core.

SECTION 4

4 CONCRETE WORKS

4.21 General

- 4.21.1 This shall be the Technical Specification for reinforced Concrete Base Construction for the said site.
- 4.21.2 The work to be executed under this specification consists of the supply and placement of concrete and ancillary requirements like site preparation.
- 4.21.3 Material and workmanship shall conform to the relevant S.A.A Codes or equivalent Codes approved by DBGGA.
- 4.21.4 Refer to NOTES on Structural Drawings.

4.22 Reference Documents

- 4.22.1 Documents reference in this Specification are listed in full below whilst being cited in the text in the abbreviated form or code indicated.
- 4.22.2 Australian Standards
- AS 1012.1-Sampling fresh concrete
 - AS 1012.3.1-Determination of properties related to the consistency of concrete Slump Test
 - AS 1012.8-Making and curing concrete compression, indirect tensile and flexure test specimens in the laboratory or in the field.
 - AS 1012.9-Determination of the compressive strength of concrete specimens
 - AS 1012.14-Securing and testing cores from hardened concrete for Compressive strength
 - AS 1141.14-Particle shape by proportional calliper
 - AS 1141.21-Aggregate crushing value
 - AS 1302-Steel reinforcing bars for concrete
 - AS 1303-Steel reinforcing wire for concrete
 - AS 1304-Welded wire reinforcing fabric for concrete
 - AS 1379-The specification and manufacture of concrete
 - AS 1478-Chemical admixtures for concrete
 - AS 2271-Plywood and blackboard for exterior use
 - AS 2758.1-Concrete aggregates
 - AS 3600-Concrete structures
 - AS 3610-Formwork for concrete
 - AS 3972-Portland and blended cements

4.23 Alignment

- 4.23.1 The Contractor shall be responsible for setting out the concrete base accurately to line and level in accordance with the instruction supplied, and arrangements must be made with MSAF/DBGA to have the setting out checked prior to the work commencing. All spalling of concrete and fragments of previous concrete base shall be removed and disposed properly. No stockpiling of demolished material shall be left on the shores. Unless otherwise directed by DBGA.

4.24 Dimensions

- 4.24.1 Base: The confirmed size of the base is to be as per stated in the structural drawing, all relevant specification on the drawings related to the concretion of this base is to be followed or as per the instruction provided by MSAF/DBGA.

4.25 Materials

- 4.25.1 CEMENT: Shall be standard Portland and cement of approved manufacture delivered to the site in sealed bags as provided by the manufacturer. No cement showing signs of lumping shall be used; no re-bagged cement shall be delivered to the site. Cement shall be stored off the ground in a clean, dry, weatherproof construction specifically constructed for and exclusively used for this purpose. Cement shall be used as nearly as practicable in the order in which it is delivered to the site.

- 4.25.2 SAND: Shall be clean coarse grained, free from silt, salt and deleterious or carbonaceous matter and where requested by MSAF/DBGGA shall be washed in fresh water. Sources of sand shall be inspected prior to transportation to the site. Sands shall be mixed if so required by MSAF/DBGGA to obtain acceptable grading.
- 4.25.3 COARSE AGGREGATE: Shall be sieved to specified grades and stock-piled separately with samples of each grade taken from time to time by MSAF/DBGGA and mix tested to suit quality and grading of these aggregates. Passing 38mm sieve and retained on 19mm sieve.
Passing 19mm sieve and retained on 6mm sieve.
Passing 6mm and retained on No.14 sieve.
- 4.25.4 WATER: Shall be potable (drinkable), clean and fresh, free from salt and other impurities.
- 4.25.5 REINFORCEMENT: Shall be round mild steel bars complying with AS1302 or the equivalent BSS, clean and free from dirt, grease or other foreign matter. Remove all loose scale before concrete is poured. Rods shall be cold bent to the correct shapes with all hooks as shown. Wire mesh reinforcement consisting of steel fabric composed of wires or bars welded into a mesh shape constructed from steel which before welding shall comply with the requirements of British Standard Specification and shall be supplied in flat sheets. All bars over 12dia. shall be deformed complying with the BSS code for deformed bars. Unless otherwise shown or specified, the minimum clear cover to main reinforcement shall be as follows:-
- a) where concrete is in contact with ground -75mm
 - b.) under-sides of beams and all columns - 40mm
 - c.) sides of beams - 25mm
 - d.) floor slabs - 20mm
- Or else refer to the structural notes on the structural drawing
- 4.25.6 Secure alternate passing with 16 gauge black binding wire to prevent movement while concreting. Splices of reinforcement shall be made only at the points shown on drawings except with the approval of MSAF/DBGGA.
- 4.25.7 Lapping reinforcement shall be of a length as to develop the full strength of the bars. In splices the length bars shall be placed at the minimum distance apart of 1 1/2 times the diameter of the bars provided that in no case the spacing between bars less than 1 1/2 times the maximum size of the coarse aggregate. Fabric reinforcement shall be lapped to develop the full strength of the bars in both directions.

4.26 Mixing

- 4.26.1 GENERAL: Concrete shall be mixed only in the quantities required for immediate use. The use of partly hardened concrete or remixing of such without additional cement, aggregate or water, will not be permitted.
- 4.26.2 MACHINE MIXING: Concrete shall be mixed in batch mixes of an approved type or types which will ensure uniform distribution of the ingredients throughout the mass. During mixing, the drum shall be rotated at the manufacture or, where no such recommendation has been made, at the

speed of not less than fourteen (14) or more than twenty (20) revolutions per minute.

The mixers shall be in good operating condition and the interior of the drums and the mixing blades shall be kept thoroughly clean and free of hardened concrete or mortar. Mixing shall be continued for a minimum of one and a half (1 1/2) minutes after all the ingredients are in the mixer before any portion of the batch is discharged.

4.26.3 HAND MIXER: Mixing by hand shall not be permitted except in an emergency and then only subject to the approval of MSAF/DBGA.

4.26.4 PRE-MIXING: Concrete which has been mixed in an approved central plant and transported to the site in a pre-mixed condition by means of specially constructed conveyance or transit mixers will be accepted, provided that it complies in all respects with the requirements of this specification and AS139 "Ready Mixed Concrete" or the equivalent British Standard Specifications.

4.26.5 The Contractor must notify MSAF/DBGA two (2) days in advance of his intention to use ready-mixed concrete to enable arrangements to be made for MSAF/DBGA or his representative to be present at the plant and/or the site during placing.

4.26.6 The Concrete shall be discharged at the site within 1 1/4 hours after the cement and water have been added to the mix in the factory and shall be placed in position within fifteen (15) minutes after discharges.

4.27 Tests

4.27.1 Compression Test: The Contractor shall allow the taking of three concrete test cylinders, either (304.8) (152.4) per concrete pour, or, as may be directed by MSAF/DBGA. These cylinders may be taken from any random delivery by MSAF/DBGA and shall be cured on site in conditions as near as possible to those under which the pour were taken when being cured. The cylinders shall be prepared from a representative sample of the delivery.

Concrete Strength: Unless otherwise stated, the characteristic strength of the concrete shall be as follows:

30 MPa generally

All concrete shall be ready mixed unless otherwise approved.

4.28 Consistency

4.28.1 Slump tests, in accordance with AS102 part 3 or relevant British Standard Specification shall be made by the Contractor at least once a day at the commencement of work and at such other times as MSAF/DBGA may require. The Contractor shall provide all materials, labour and facilities required for this purpose, including the necessary standard mould. The consistency of the concrete shall be such as to produce slump, under test within the following ranges:

4.28.2 footings, retaining and other walls - 50 to 70 mm

4.28.3 floor slabs - suspended & on ground -25 to 75 mm

4.28.4 Beams and columns - 50 to 75mm

4.29 Placing

- 4.29.1 All concrete shall be finally placed in position within 30minutes of leaving the mixer. It shall be minimum handling between the mixer and the final position and shall not be allowed to drop freely more than 180mm. Placing should be in uniform layers, well vibrated by approved mechanical electrical vibrator to consolidate concrete without segregation.
- 4.29.2 Concrete shall be placed in daylight or under such lighting conditions as may be approved by MSAF/DBGGA.
- 4.29.3 No concrete shall be placed until reinforcement and formwork have been inspected and approved by MSAF/DBGGA. Twenty four (24) hours notice shall be given to MSAF/DBGGA of the intention to place concrete.
- 4.29.4 Prior to commence placing of concrete, the concrete surface of all appliances to be used for this work shall be thoroughly cleaned of all hardened concrete or foreign matter. Formwork shall be cleaned of debris and free of water.
- 4.29.5 Concrete shall not be deposited in wet trenches or in running water.
- 4.29.6 Concrete shall be conveyed from the mixers to the place of final deposit without delay and by methods which will not cause or permit segregation and/or loss of materials. It shall be transported on substantial gangways supported above the reinforcement by trestles resting on the formwork.
- 4.29.7 Each monolithic portion of the work shall, except where the use of construction joints us approved, be placed in one continuous operation. The order of placing shall be as required by MSAF/DBGGA and shall be so arranged that new concrete is continually being placed against unset concrete so that a monolithic structure will result.
- 4.29.8 No concrete which has partially hardened or has contaminated by foreign materials shall be deposited in the work. Re-tempered concrete shall not be used.
- 4.29.9 Concrete shall not be placed at a rate greater than that which will permit satisfactory compaction or to a depth greater than 450mm before compaction thereof. The Contractor shall, at all times provide adequate labour to ensure that the concrete is compacted in the forms to the satisfaction of MSAF/DBGGA.
- 4.29.10 If ready-mixed concrete is used, the Contractor must organize the delivery of concrete to the site in such quantities as can be efficiently handled by the labour available.
- 4.29.11 All vertical members including walls shall be placed and compacted at least twelve (12) hours before any horizontal members (including reinforcement) which they support, are placed.

4.30 Compaction By Hand

- 4.30.1 Where mechanical vibration cannot be used, as determined by MSAF/DBGGA, the concrete shall be thoroughly compacted by means of continuous stamping, spading and slicing during and immediately after placing. Care shall be taken to fill every part of the forms, to work the concrete under and around the reinforcement without displacing it, to work coarse aggregate back from the faces and to remove all air bubbles and voids.

4.31 Compaction By Mechanical Vibration

- 4.31.1 Mechanical vibration shall be used throughout for compacting the concrete.
- 4.31.2 Vibrators shall be of an approved type transmitting not less than 9,000 impulses per minute when under load.
- 4.31.3 Vibrators shall be operated to the satisfaction of DBGA. They shall be uniformly spaced and not further apart from 600mm of the radius beyond which vibration is visibly effective. They shall be provided in sufficient number to ensure compaction at a rate satisfactory to DBGA. In addition, at least one vibrator of each type shall be kept in reserve for emergency use. Vibrators shall be moved continuously throughout the wet concrete and shall not be allowed to remain in any one position for more than 10 seconds.
- 4.31.4 Vibration should achieve uniform density of the concrete but should not be continued to the extent that localized areas of void are formed. Particular care shall be exercised to avoid damage to partially set concrete.

4.32 Poor Compaction

- 4.32.1 If in the opinion of MSAF/DBGA the concrete when exposed by stripping the forms, is incompletely compacted, the Contractor shall immediately hack back, removing all laitance and make good the honeycombed areas with a 3:1 sand and cement mortar while the concrete is still green. The Contractor shall reconstruct at his own expense any structural members or portions of the work which are shown to be faulty, either by tests or inspection.

4.33 Construction Joints

- 4.33.1 The location of construction joints shall be planned in advance and shall be approved by MSAF/DBGA prior to commencement of concreting.

4.34 Protection

- 4.34.1 Freshly cast concrete shall be protected from premature drying and excessively hot or cold temperatures. In windy conditions, windbreaks shall be erected to shield the concrete surface during and after placing. The concrete shall be maintained at a reasonably constant temperature with minimum moisture loss for the curing period.
- 4.34.2 The responsibility for the curing and protection of the concrete shall rest entirely with the contractor. Curing methods which do not conform to this specification shall be rejected.

4.35 Curing

- 4.35.1 All exposed surfaces of concrete shall be cured by one of the following methods:
- 4.35.2 Ponding or continuous sprinkling with water.
- 4.35.3 Covering with an impermeable membrane concrete that has taken its initial set and that has been moistened with a fine spray of water. The covering materials shall be held firmly against the concrete for the full length of all edges and laps and at frequent intervals between so that there shall be no air circulation at the concrete surface.

- 4.35.4 The use of an absorptive cover, kept continuously wet. The use of the curing compounds conforming to ASTM C309 are not permissible except with DBGA's approval in writing.

4.36 Curing Period

- 4.36.1 Curing shall commence immediately after initial set of concrete and shall continue for 7 days.

4.37 Damage

- 4.37.1 The concrete shall be protected from damage due sea swells, heavy shocks and excessive vibration, particularly during the curing period.
- 4.37.2 All finished concrete surface shall be protected from damage due to any cause such as construction activities, rain and running water. Self-supporting structures shall not be loaded in any way which will overstress the concrete.

4.38 Tolerances

- a. sides of members and thickness of slabs:
+6mm, - 0mm
- b. surfaces: 3mm, -3mm to 3m long straight edge
- c. surface deviation: +1.5mm, -1.5mm in 300m
- d. abutting surfaces at joint: 1.5mm, -1.5mm

4.39 Building-In

- 4.39.1 Allow for all sub-contractor's work. Building in all metal work etc.
- 4.39.2 Form all openings; set-downs etc. keep all exposed bolt threads clean.
- 4.39.3 Build in all under floor pipeworks, leave sleeve for drains, pipes etc. as necessary.

4.40 Formwork

- 4.40.1 Formwork shall conform with SAA Codes AS1082, AS1510 or equivalent BSS. The responsibility for the sufficiency of the whole of the formwork shall rest entirely with the Contractor. Formwork shall be constructed from sound materials properly supported and braced or tied to maintain position and shape during and after the placing of concrete. Formwork shall be supported in a manner which will prevent its settlement. Formwork shall be kept in place for 3 days at column and beam sides and 14 days for soffits generally and to MSAF/DBGA's approval and in accordance with SAA Codes AS1082, AS1509 and AS1510 or equivalent BSS.

4.41 Concrete Surface to Receive Special Finish

- 4.41.1 Surfaces must be rough-broomed with hard bristle broom and must be free of all laitance to form key and bond with applied finish.
- 4.41.2 All surfaces must be roughened to the satisfaction of the Special Finish Applicator.
- 4.41.3 All surfaces not accepted by the Special Finish Applicator must be fixed at the Contractors own expense.

SECTION 5**5 FABRICATION AND ERECTION OF ALUMINIUM****5.1 General**

This Technical Specification applies to the fabrication and erection of structural aluminium towers and other structures.

Structural aluminium work shall be fabricated only by a fabricator which is registered and licenced under the relevant authority.

Refer to NOTES on Structural Drawings.

5.2 Materials

5.2.1 All Aluminium to be Alloy 6061 T5/T6. When specified on MSAF/DBGGA drawings, material manufactured to other standards will be accepted provided the material comply with the appropriate ASTM standards.

5.2.2 The quality of all materials used in the execution of this contract shall comply with the requirements of the following Standard Specification:

AS/NZS 1664	Aluminium Structures limit state design
AS 1665	Welding of Aluminium Structures
AS 1734	Aluminium and aluminium alloys – Flat sheet, coiled Sheet and Plate
AS 1865	Aluminium and aluminium alloys – Drawn wire, rod, bar and strip
AS 1866	Aluminium and aluminium alloys – Extrude rod, bar, solid and hollow shapes
AS 1867	Aluminium and aluminium alloys – Drawn Tubes
AS 2848	Aluminium and aluminium alloys – Composition and Designations
ASTM B 557	Test methods of tension testing wrought and cast aluminium – and magnesium alloy products
ASTM D 962	Specification for aluminium powder and paste pigments for paints
ASTM E 330	Test method for structural performance of exterior windows, curtains walls and doors by uniform static air pressure difference

5.2.3 The Contractor shall supply to MSAF/DBGGA prior to the commencement of fabrication copies of the aluminium material test certificate and showing the chemical properties.

5.2.4 MSAF/DBGGA may at any time require any materials to be tested in accordance with the requirements of the listed specifications.

5.2.5 The Contractor shall, if required, promptly supply at his expense, test pieces as required by MSAF/DBGGA.

5.3 Shop Drawings

- 5.3.1 Before fabrication is commenced, the Contractor shall prepare shop drawings. These drawings shall clearly show all sizes, markings and corrections and set out the positions, sizes, and lengths of all welds as necessary for the complete fabrication, assembly and erection of the tower
- 5.3.2 No fabrication shall be commenced for any variation or substitutions made in the shop drawings unless these have been approved in writing by MSAF/DBGA.

5.4 Fabrication

5.4.1 CUTTING AND BENDING

All members, plates, brackets etc. shall be neatly and accurately sheared, sawn or profited to the required shape as shown on the drawings. After cutting, all rough edges shall be ground off.

5.4.2 PUNCHING AND BORING

All holes for bolts must be punched with holes 1.5mm larger in diameter than the bolts used. Holes for bolts in material thicker than 16mm must be drilled or sub-punched and reamed.

5.4.3 BOLTING

All bolts used shall be of such lengths that at least one full thread is exposed beyond the nut after the nut has been tightened.

Where a nut or bolt-head would bear on an inclined surface a bevelled washer of the correct size shall be interposed between the two surfaces. Bevelled washers shall not be allowed to get out of position during fabrication and erection for this purpose may be spotted to the steel surface.

5.5 Welding Consumables

- 5.5.1 Welding consumables shall be compatible with the parent metal and shall be classified and identified in accordance with the provisions of AS 1665.

5.6 Electric Welding

- 5.6.1 Welding shall be carried out in accordance with the provisions of AS 1665. All manual welding shall be carried out in accordance with standard. If the Contractor is desirous of using semi or fully automatic welding equipment, he shall submit to MSAF/DBGA a complete specification of equipment, electrodes, fluxes. In addition, details of joint preparation, welding, procedures and preheat. The Contractor shall be required to demonstrate to MSAF/DBGA his procedures and shall have his written approval before commencement of fabrication.
- a. Joint preparation shall be executed in accordance with the above mentioned code and as detailed on the drawings. Preparation shall be carried out by planning or machine flame cutting the prepared surfaces shall be free from loose scale, slag, rust, grease, tears, and fins.
 - b. Before commencing welding, sections to be butt welded shall be aligned with 1.5mm of their gap at the roof of the weld shall not exceed 0.75mm.

- c. All welds shall be of the finished sizes specified and but in such sequence as will cause the minimum distortion of the parts welded.
- d. Multiple run welds shall be carried out with each run closely following the previous run but allowing sufficient time for the proper removal of slag. Each run will be inspected and unsatisfactory weld must be cut out and remade to approval.
- e. Welds shall on completion present a reasonably smooth and regular finish free from defects.
- f. Unless otherwise shown, the minimum size of fillet shall be 6mm.
- g. Not less than three working days prior to any welding commencing on any butt weld joint, the Fabricator shall notify MSAF/DBGA, the butt weld preparations are available for inspection. Welding shall not start until MSAF/DBGA has reviewed.

5.7 Inspection of Completed Product

- 5.7.1 Not less than three (3) working days after the completion of the fabrication of the aluminium component, notify MSAF/DBGA the product is available for inspection.
- 5.7.2 MSAF/DBGA shall ensure, for all aluminium fabricated product, the following inspections are undertaken:
 - 100% of all products shall be visually examined, and
- 5.7.3 Any welding defects found during the inspection shall be repaired prior to the application of the protective coating.

5.8 Aluminium Bolts, Nuts and Washers

- 5.8.1 Bolts used for the erection of structural aluminium must be aluminium or made from stainless steel conforming to ASTM A276 Grade316. Bolts must be copper free.
- 5.8.2 The bolt supplier shall supply the fabricator with a certified material test certificate outlining the chemical composition and mechanical properties of all bolts supplied. The test certificate shall be able to be traced back to the batch of bolts.

5.9 Handling and Storage of Aluminium Components

- 5.9.1 At all times, handle and store structural aluminium members so that the material, protective coatings and parts are kept clean and free from damage.
- 5.9.2 Place aluminium to be stored on supports above the ground. Place and store girders and beams upright. Prefabricated truss segments may be stored in the horizontal position. Adequately support all members and segments at points sufficiently close together to prevent damage from deflection.
- 5.9.3 Sort and store all small articles, such as bolts, loose splice plates etc., above ground.
- 5.9.4 Tools used to fabricate or assemble stainless steel components shall be dedicated tools for aluminium work. Tools previously used on carbon steel shall not be used for stainless steelwork.

5.9.5 Aluminium material shall be wrapped or otherwise protected during transport to avoid contamination. If an adhesive plastic film is used all traces of adhesive shall be removed from the steel with a suitable solvent.

5.9.6 Webbing slings shall be used in lifting aluminium components and not chains. Grinding, cutting and welding shall not be carried out over open bundles of aluminium components.

5.10 Delivery

5.10.1 Take delivery of aluminium ex-factory and transport to the site in good condition and replace any members bent or twisted in transit.

5.11 Erection

5.11.1 All erection shall be carried out by competent and experienced men and the contractor shall take every care to safeguard the public, workmen and adjoining property.

5.11.2 All gear used shall be adequate strength and shall comply with all regulations current at the time and all steelworks shall be adequately bolted, guyed and braced to make the structure secure. The Contractor shall be held responsible for all damage caused to the structure, works or buildings during erection.

5.11.3 In making corrections, drifting of unfair holes will not be permitted and holes not matching properly shall be reamed or drilled out and a larger bolt inserted with MSAF/DBGAs approval.

5.11.4 No member or part of member which has bent or distorted shall be erected in that condition, all straightening shall be done on the ground and checked by MSAF/DBGAs.

5.11.5 All bolts shall be left tight, and all bevelled washers and plates properly positioned.

5.11.6 Column shall be wedged to line and level on steel or cast-iron wedges and checked by MSAF/DBGAs. After acceptance column bases shall be caulked to approval before wedges are removed.

5.11.7 Unless shown on the drawings, all columns shall be left truly vertical and correct to line and level.

5.12 Minor Parts

5.12.1 If neither the Specification, drawings nor schedule of quantities contains any particulars of minor parts, nor which parts are obviously necessary for the proper complement of the work, all such parts shall be supplied and executed by the Contractor without extra charge.

5.13 Protection

5.13.1 All mill scale, rust, dirt/or other deleterious substances shall be removed by the use of chipping hammer and then wire brushing back to clean metal.

5.13.2 All surfaces shall be thoroughly dry before coating applied.

5.14 Coating

- 5.14.1 Immediately after preparation work has been completed, apply type of primer as specified in Schedule of paint. Finishes strictly to manufacturer's instructions.
- 5.14.2 The primer shall be spray applied except where written approval is given by MSAF/DBGA to substitute brushing for spraying.
- 5.14.3 After erection all damaged portions shall be cleaned back to the satisfaction of MSAF/DBGA and made good to match original coating in thickness, texture and colour.

5.15 Assembly

- 5.15.1 Give MSAF/DBGA notice of your intention to commence assembly of members.
- 5.15.2 Accurately assemble the members and/or components as shown on the Design Documentation drawings using the identification marks. Handle the material carefully so that individual parts will not be bent, twisted or damaged in any way.
- 5.15.3 Wherever necessary, fix adequate temporary bracing to the aluminium to ensure that the parts that have been erected are stable and will not be overstressed. Leave such temporary bracing in position until sufficient permanent bracing has been installed.

SECTION 6

6 PAINTING

6.1 General

- 6.1.1 This part includes all coatings to be carried out other than those specially provided for in other parts. REFER TO DRAWINGS FOR THE PAINT SPECIFICATION.
- 6.1.2 In any case, finishing coats of the works covered by other part will be executed in conjunction with painting and surface treatments provided for in this part.
- 6.1.3 Work shall be pre-planned and executed to meet the needs of trade and services.
- 6.1.4 While work shall follow completed work sections, premature finishing coatings shall be avoided.

6.2 Materials Generally Manufactured

- 6.2.1 ALL PAINTS MUST BE ANTI- MOULD, ANTI- FUNGAL PAINT MARINE GRADE PAINT

All paints and coatings shall be of the same manufacture specific and as approved by MSAF/DBGA and comply by current S. A. A requirements for their respective kinds. All paints, primers, undercoats and finishing's coats are to be lead-free. All paint undercoat, primer, etch primer etc. shall be obtained from ONE Manufacturer.

- 6.2.2 APPLY STRICTLY TO MANUFACTURER'S INSTRUCTIONS
CONTAINERS

All materials shall be delivered in sealed labelled containers of the manufacturer of the paint.

PRIMING

(a) ALL SURFACES MUST BE INSPECTED BY MSAF/DBGGA BEFORE PRIMING AND BETWEEN COATS.

(b) All timber and plywood with mould and fungus shall be rejected and removed from site.

(c) All woodwork and metalwork to be painted shall first be primed.

(d) Priming woodwork having opaque finish shall be an approved first quality titanium primer in oil. All end grain, exposed or concealed, must have 2 coats of primer.

(e) Treatment of woodwork with clear plastic and natural timber finishes shall be as recommended by the manufacturer of the relative coat finishes.

(f) Priming for metalwork shall be a.b.s Metalwork and as allowed for in that section.

6.2.3 UNDERCOATS

(a) To all finishes shall be those recommended by the manufacturer of the relative coat finishes.

6.3 Delivery and Storage of Materials

6.3.1 Deliveries shall be made well in advance of application and shall be stored undercover or in sheds on timber platform.

6.4 Workmanship

All surfaces must be inspected by MSAF/DBGGA before painting and between coats.

All surfaces must be mould-free, fungus free before painting.

All other surfaces shall be free treated with anti-mould solution strictly to manufacturer's instruction before painting if found to have mould.

Coating shall not be applied to any surface which is not thoroughly dry except where recommended by the manufacturer or acceptable.

All surfaces shall be inspected and where defective, made good before work proceeds.

Applications of paint or stains or clear finish will be considered as acceptance of surface conditions for reception of materials by both contractor and respective paint manufacturer.

6.5 Cleaning Up Before Painting

Prior to commencement of painting, the area to be painted plus the surrounding area shall have all debris removed and then swept clean and left for a period of 4 hours after which all dust shall be removed.

6.6 Commencement

- 6.6.1 Generally no painting shall commence until; such time as the work of all other trades has been completed within the area to be painted.
- 6.6.2 Where it is necessary to lay a floor covering after the painting has been completed, the best coat shall be applied after the laying of the floor covering.
- 6.6.3 All adjacent finishes shall be adequately protected and any paint splashes removed without injury to the affected area immediately.
- 6.6.4 All work shall be performed by skilled tradesman in a neat and workman like manner, cutting in and finished edges shall be clean and straight.
- 6.6.5 All materials shall be mixed and applied in strict accordance with the manufacturer's printed recommendations.
- 6.6.6 Concrete and grano pavings which have been splashed with paint shall be taken up and re-laid and all costs involved shall be borne by the Contractor. If walls are damaged in effecting any relaying, they shall repainted at the contractor's expense.
- 6.6.7 Surfaces shall be rubbed down before painting. Each shall be well rubbed down and/or washed down as required prior to the application of the following coat. The exception is stain coating which is not rubbed back between coats.
- 6.6.8 Application of paint shall not be carried out in wet and/or windy weather. The latter is to be at the discretion of MSAF/DBGGA.
- 6.6.9 Galvanized or rustproof surfaces shall be left until last for painting.
- 6.6.10 Undercoats shall be tinted differently from the preceding coat and each approved before the next coat is applied.
- 6.6.11 Except where otherwise specified or approved, all paint shall be applied with first quality brush ware.
- 6.6.12 Paint shall be brushed on thoroughly and laid off so that no brush marks show on the finished area.
- 6.6.13 Samples of each colour and finish shall be prepared on selected surfaces for approval by MSAF/DBGGA before painting commences. A sample shall not be less than 0.4sq.m.
- 6.6.14 Where certain colours may require tinting and/or intermixing shall only be done with paints of the same manufacturer.

6.7 Finishes

- 6.6.15 Opaque Finishes: Full Gloss paint shall be approved quality, high gloss opaque alkyed paint. It shall be non-toxic, lead free, having high resistance to abrasives, fair resistance to chemicals and solvents.
- 6.6.16 Full Gloss Enamel: shall be an approved first quality, high gloss opaque alkyed enamel. It shall be non-toxic, lead free, having high resistance to abrasive, fair resistance to chemical and solvents.
- 6.6.17 Semi-Gloss Acrylic: shall be an approved semi-gloss opaque, water borne, acrylic paint. It shall be non-toxic, lead free, having very good resistance to abrasive, high resistance to chemicals and solvents.

- 6.6.18 Flat Acrylic: shall be approved flat, opaque water based acrylic paint. It shall be nontoxic lead free having good resistance to abrasives, chemicals and solvents.
- 6.6.19 Polyurethane finish shall be an approved oil rich timber stain containing a combination of natural oils, preservatives and water proofing compounds. Clear Stain finish shall be an approved oil rich timber stain containing a combination of natural oils, preservatives and water proofing compounds. Special waterproof coating (if applicable) shall be supplied and applied by a specialist sub-contractor or obtained from a specialist supplier and applied in accordance.

- 1 coat primer
- 2 coats high gloss finishing
- 2 coats industrial finishing

Refer the structural drawing as well for the name and type of paint.

6.7 Making Good

Make good a.b.s. 'Preliminaries' in addition by cracks appearing in paintwork before expiration of maintenance period shall be made good and the surface on which the cracks occur, repainted to the satisfaction of MSAF/DBGGA.

6.8 Paint Type

All clear finish, stain and paint, undercoat, primer, equipment, filler, sealer anti-mould solution etc. shall be obtained from ONE Manufacturer.

TENDER EVALUATION CHECKLIST

CLAUSE	BRIEF REQUIREMENTS OF THE TENDER	Yes	No	N/A
1	Brief Background/History of Company including details of Parent Companies and subsidiaries.			
2	Certified Copy of Valid Company Registration Certificate (Local/Overseas).			
3	Local Bidders to provide quotes which include Duty, VAT and delivery-to-site on an "as and when required" basis. Overseas bidders to provide quote which include Cost, Freight & Insurance to the port of Suva.			
4	Certified Copy of Valid FRCS Compliance Letter			
5	Certified Copy of Valid FNPF Compliance Letter.			
6	Complete tender forms with relevant information and furnished with other tender documents.			
7a	Separate Quoting for each item and not on whole lot basis.			
7b	Price should be valid for a period of 90 days from the closing date of tender.			
8	Evidence of the business relationship: a. List all Partner(s)/Supplier(s)/Subcontractors. b. Attach letter(s) from each Partner/Supplier/Subcontractor to confirm the business relationship (for all applicable).			
9	The payment mode should be upon satisfactory execution of the order in compliance with the tendered prices, delivery time & full supply of quantity ordered.			
10	Submission of bids to be on official letterhead, clearly written or typed and signed with all relevant contact details clearly specified.			
11(a)	Currency used:			
11(b)	Back-up services			
12	Company Insurance			
12(a)	Delivery time /availability or Completion period / plan			
13	Product samples and technical literatures brochures/photos to be submitted.			
14	Warranty period for the item / Defects Liability Period to be stated.			
15	Financial Statement for 3 years			
16	MSAF Form (Company Particulars) to be fully completed.			



Company Particulars

Name			
Date of Regⁿ			
Registered Office	----- ----- -----		
Postal Address	----- ----- -----		
Telephone		Facsimile	
Email		Website	
Principal Activities	----- ----- -----		
Directors	----- ----- -----		
Share Capital Authorised Issued&Paid-Up	----- -----		
Accountant			

The undersigned attest that the above information is true and correct as of the date hereby given.

Name: Name:
 Signature: Signature:
 Designation: Designation:

Date.....

Company
Stamp/Seal

SECTION 4: STRUCTURAL DRAWINGS

for the

Fabrication, Supply & Construction of Makogai Island Lighthouse

PROPOSED LIGHT TOWER
for
MAKOGAI ISLAND

drawing schedule

STRUCTURAL DRAWINGS :

- 01 - FOUNDATION PLAN
- 02 - FLOOR PLAN
- 03 - ELEVATION
- 04 - FRAMING ELEVATION
- 05 - LIGHT STAND DETAIL
- 06 - LADDER DETAIL
- 07 - DOOR DETAIL & PLATE DETAILS

structures section

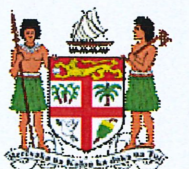

A3 ORIGINAL PAPER SIZE

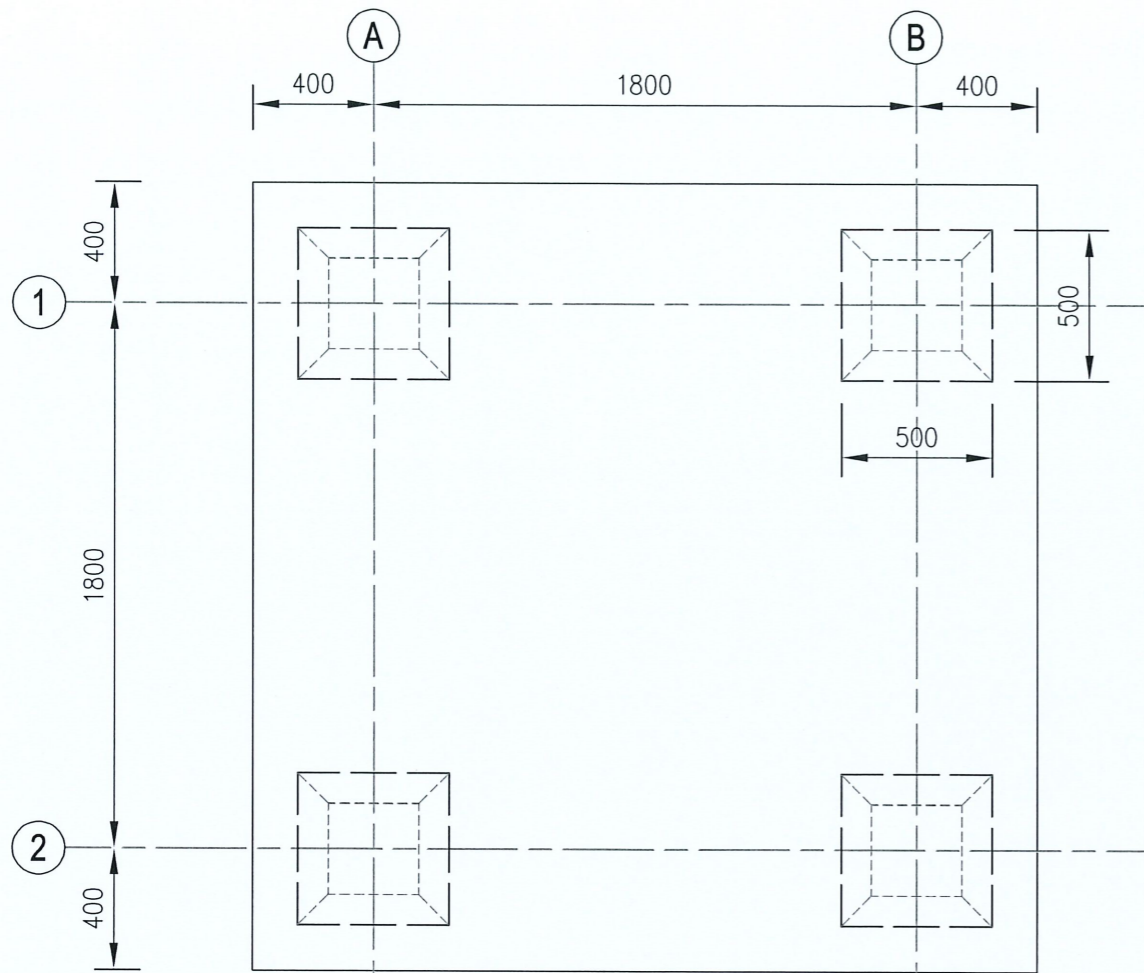

FOUNDATION PLAN
SCALE 1:25

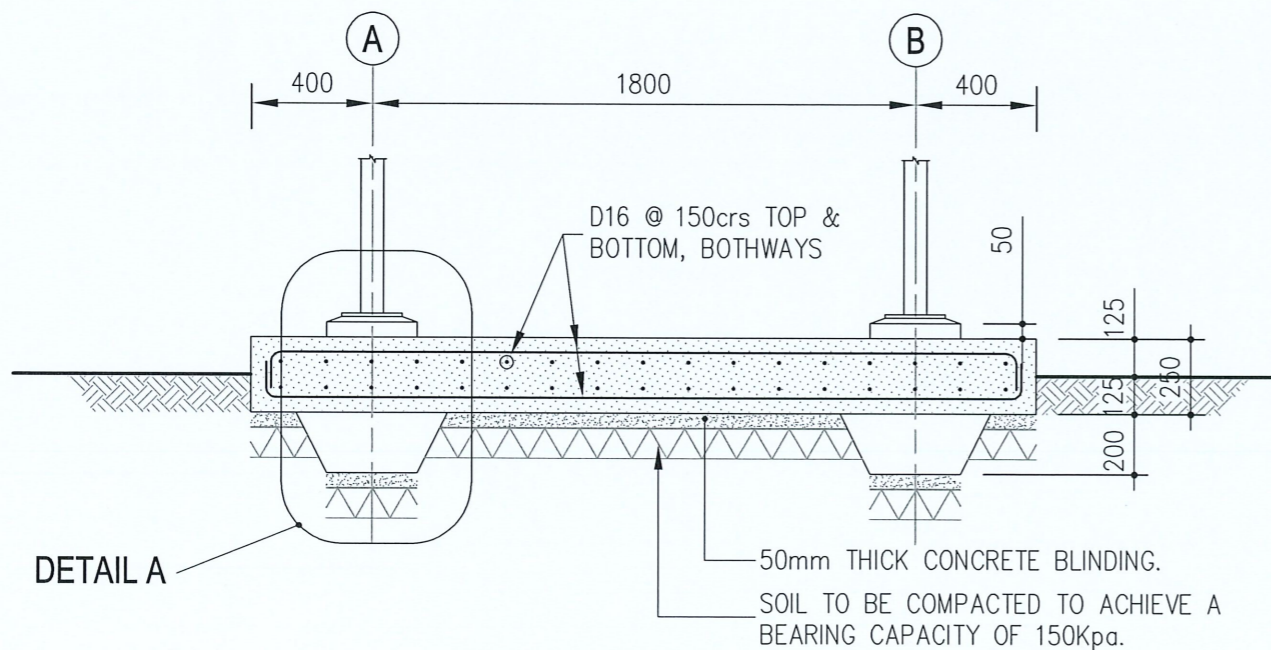

CROSS SECTION
SCALE 1:25

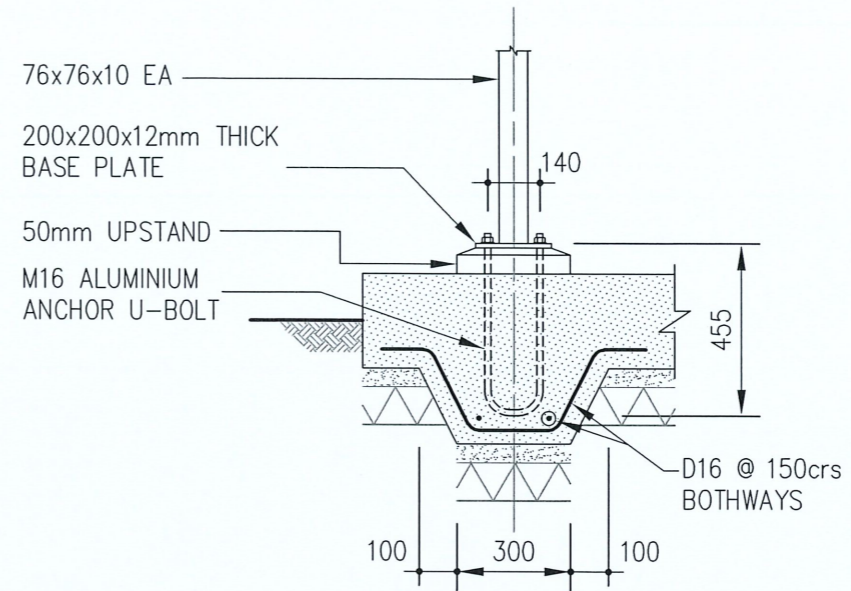

DETAIL A
SCALE 1:20

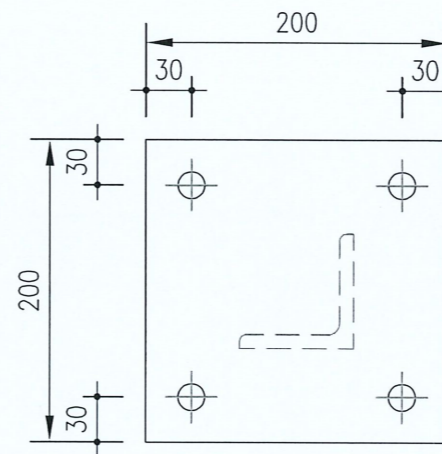

($\phi 12$ mm THICK ALUMINIUM PLATE DRILLED WITH 4No. $\phi 18$ mm HOLES TO SUITE 16mm HOLDING DOWN BOLTS)

BASE PLATE
SCALE 1:5

- NOTES**
1. SITE LOCATION
LAT 17° 26.97'S
LONG 178°57.73'E
 2. ALL DIMENSION ARE IN MM OR ELSE OTHERWISE STATED.
 3. DENOTED DIMENSIONS TAKE PRECEDENCE OVER SCALED DIMENSION.
 4. ALL CONCRETE ELEMENTS TO HAVE A MINIMUM CHARACTERISTIC COMPRESSIVE STRENGTH (f'_c) OF 30MPa @ 28 DAYS.
 5. SOIL UNDER COLUMN PADS TO BE COMPACTED TO ACHIEVE A BEARING CAPACITY OF 150KPa.

no.	date	details

amendments
This drawing and all its contents is the property of MPWTMS Structures Section any unauthorized employment or reproduction in full or part is forbidden

approval	
approval	

client
MARITIME SAFETY AUTHORITY of FIJI
LEVEL 4, KADAVU HOUSE

perm. sec. for P/IN/ST	section head	
T. Vakadravuyaca	A.Pene	
principle architect	project architect	
K. M. Zahidul	MA	
surveyed	designed	drawn
MA	MA	MA
checked	date	head subhead
	Sept 23	
		plot date
		18/09/2023

MINISTRY OF PUBLIC WORKS TRANSPORT & METEOROLOGICAL SERVICES

PROPOSED LIGHT TOWER FOR MAKOGAI ISLAND

block/sub proj.

FOUNDATION PLAN

scale: As Indicated
connected drawings

location no.		file no.	

project no.		sheet no.	
STR 1429		01	
			amend

TENDER COPY

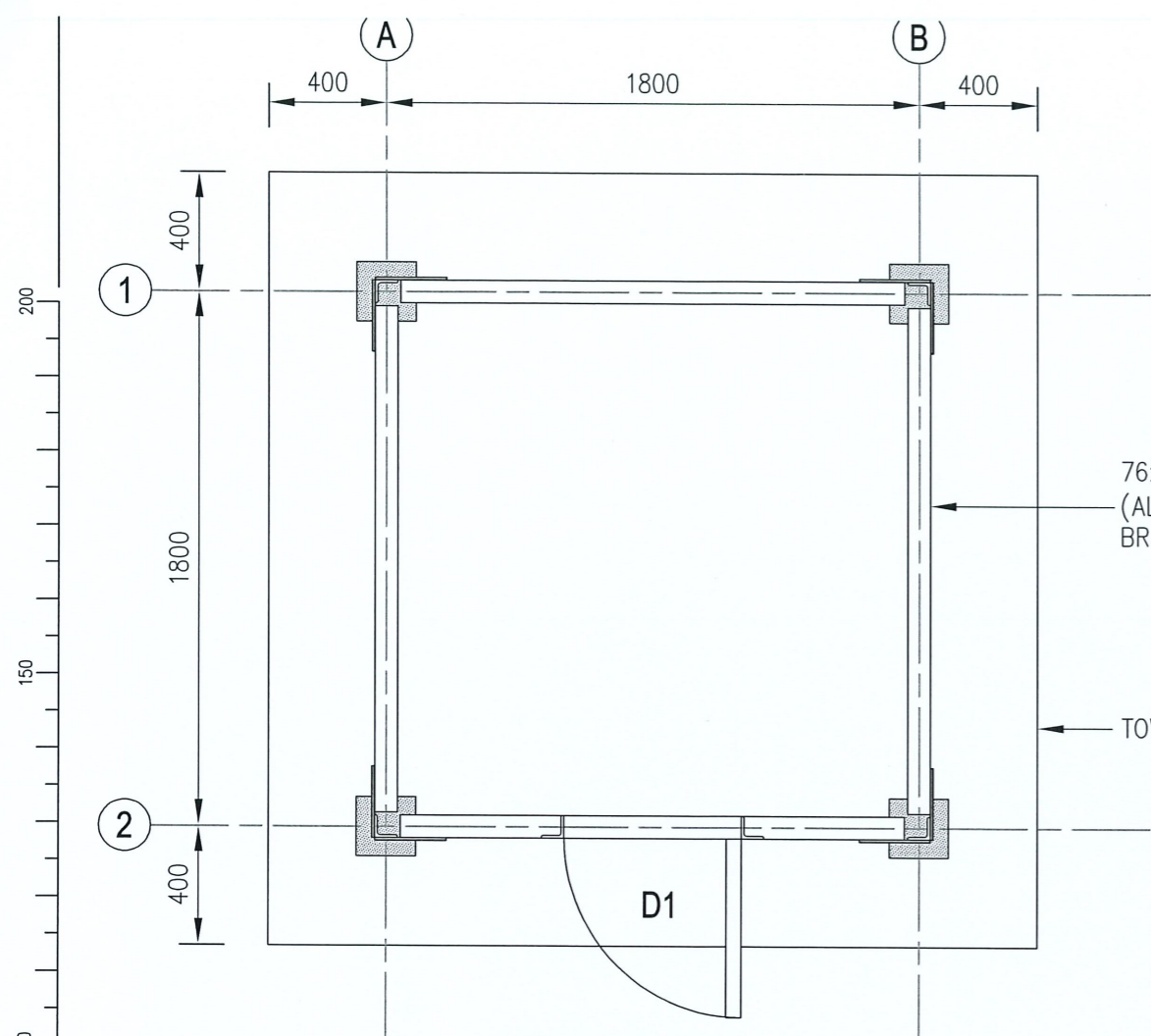

GROUND FLOOR PLAN
SCALE 1:25

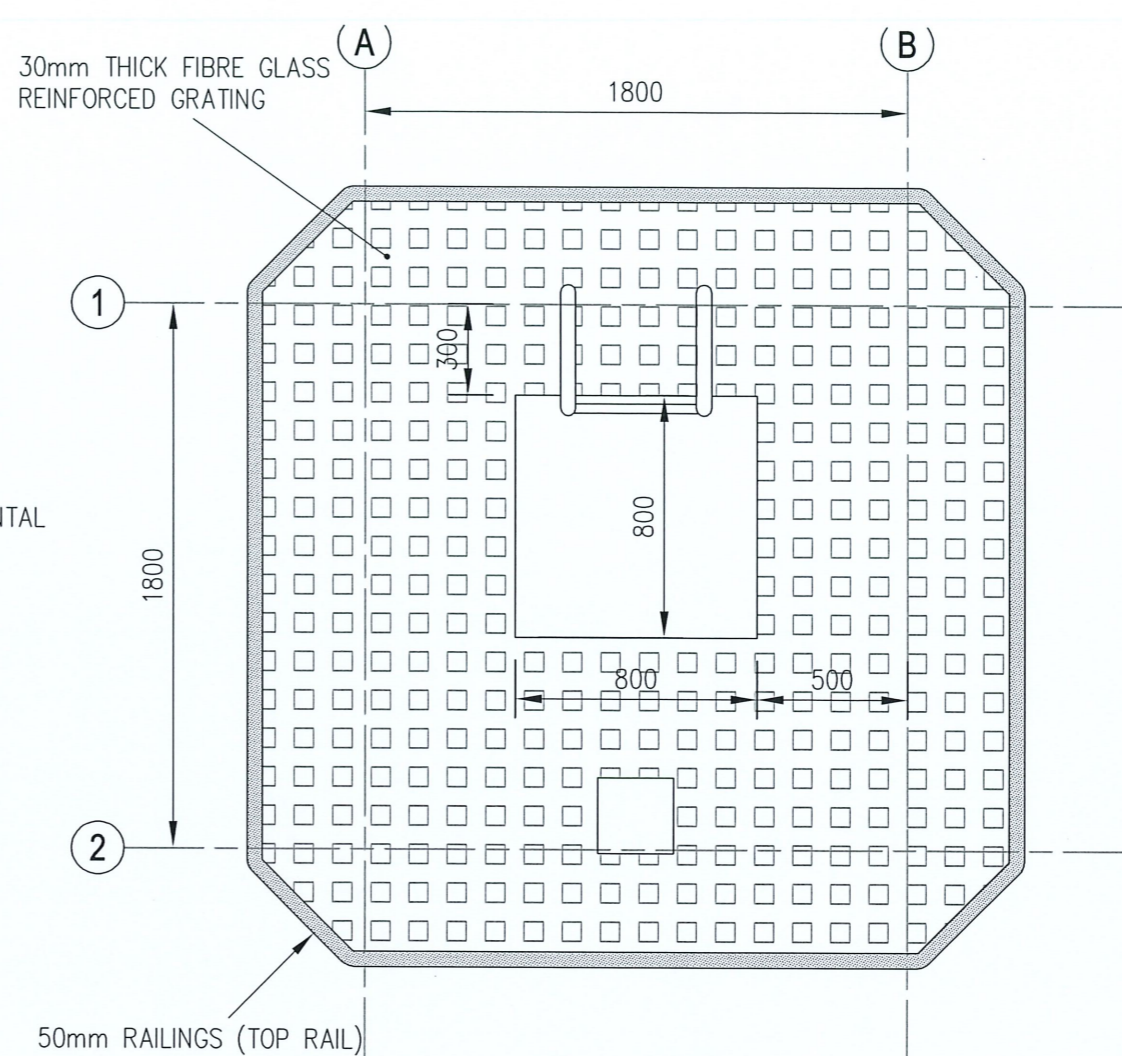

FIRST FLOOR PLAN
SCALE 1:25

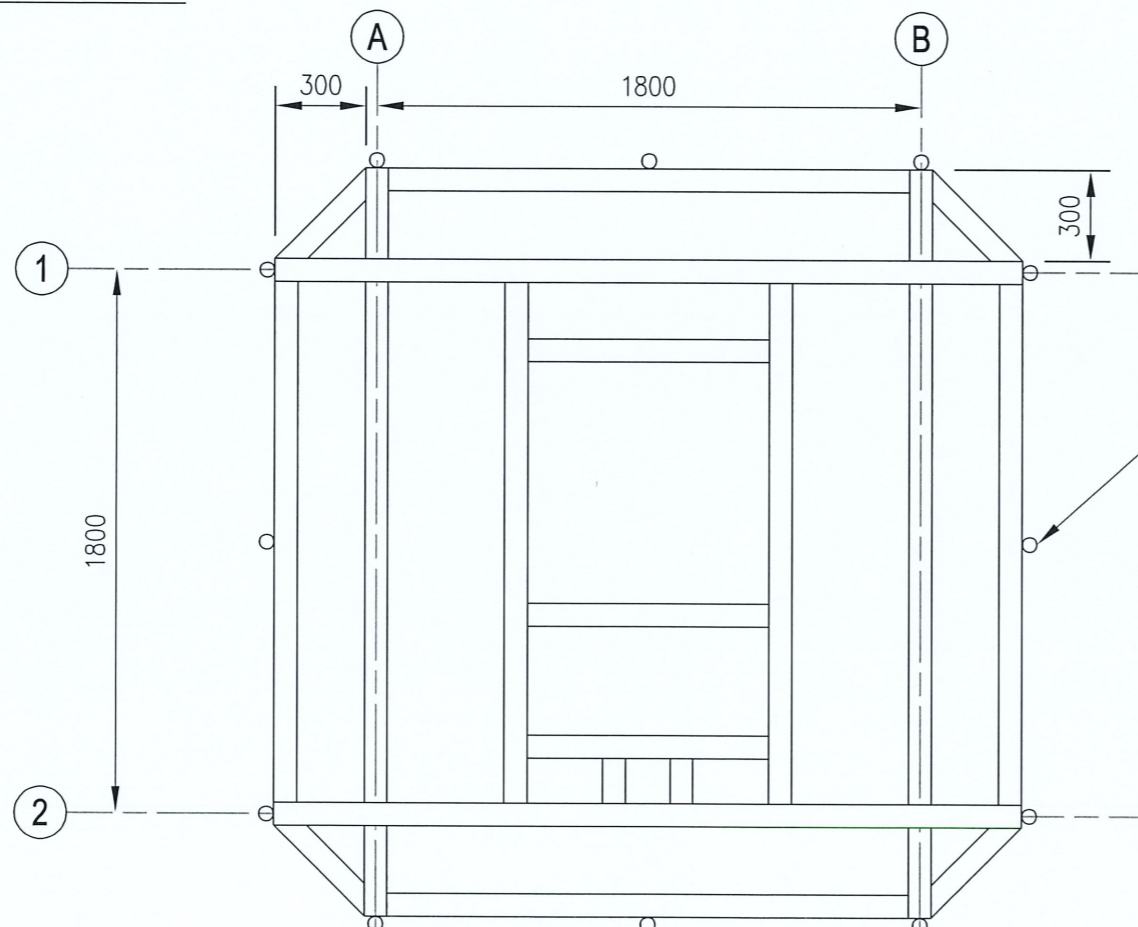

FIRST FLOOR FRAMING PLAN
SCALE 1:25

ALL FRAMING MEMBERS TO BE
76x76x10mm EA (ALUMINIUM)

TENDER COPY

6. **HARDCORE FILL TO BE WELL COMPACTED USING A 'WACKER PACKER' IN LAYERS OF 150MM TO ACHIEVE AN ALLOWABLE CAPACITY OF 150KPa.**
7. **DAMP PROOF MEMBRANE PLACED UNDER ALL CONCRETE AGAINST GROUND AND SIDES WITH MINIMUM LAP OF 150MM.**
8. **SOIL UNDER COLUMN PADS TO BE COMPACTED TO ACHIEVE A BEARING CAPACITY OF 200KPa.**
9. **RIVER GRAVEL NOT TO BE USED IN CONCRETE AGGREGATES. USE CRUSH METAL 15-20mm SIZE.**
10. **ALL ALUMINIUM MEMBERS TO BE STRUCTURAL GRADE**

no. date details

amendments

This drawing and all its contents is the property of MPWTMS Structures Section any unauthorized employment or reproduction in full or part is forbidden

approval

approval

client

MARITIME SAFETY AUTHORITY of FIJI
LEVEL 4, KADAVU HOUSE

perm. sec. for PWMTS	section head		
T. Vakdravuyaca	A.Pene		
principle arch/eng	project arch/eng		
K. M. Zahidul	MA		
surveyed	designed	drawn	amend
	MA	MA	
checked	date	head subhead	plot date
	Sept 23		18/09/2023

MINISTRY OF PUBLIC WORKS TRANSPORT & METEOROLOGICAL SERVICES

project

PROPOSED LIGHT TOWER FOR MAKOGAI ISLAND

block/sub proj.

drawing title

FLOOR PLAN

scale

As Indicated

connected drawings

location no.	building no.	file no.	
project no.	sheet no.	amend	
STR 1429	02		

A3 ORIGINAL PAPER SIZE

A3 ORIGINAL PAPER SIZE

PLOT DATE 18/09/2023

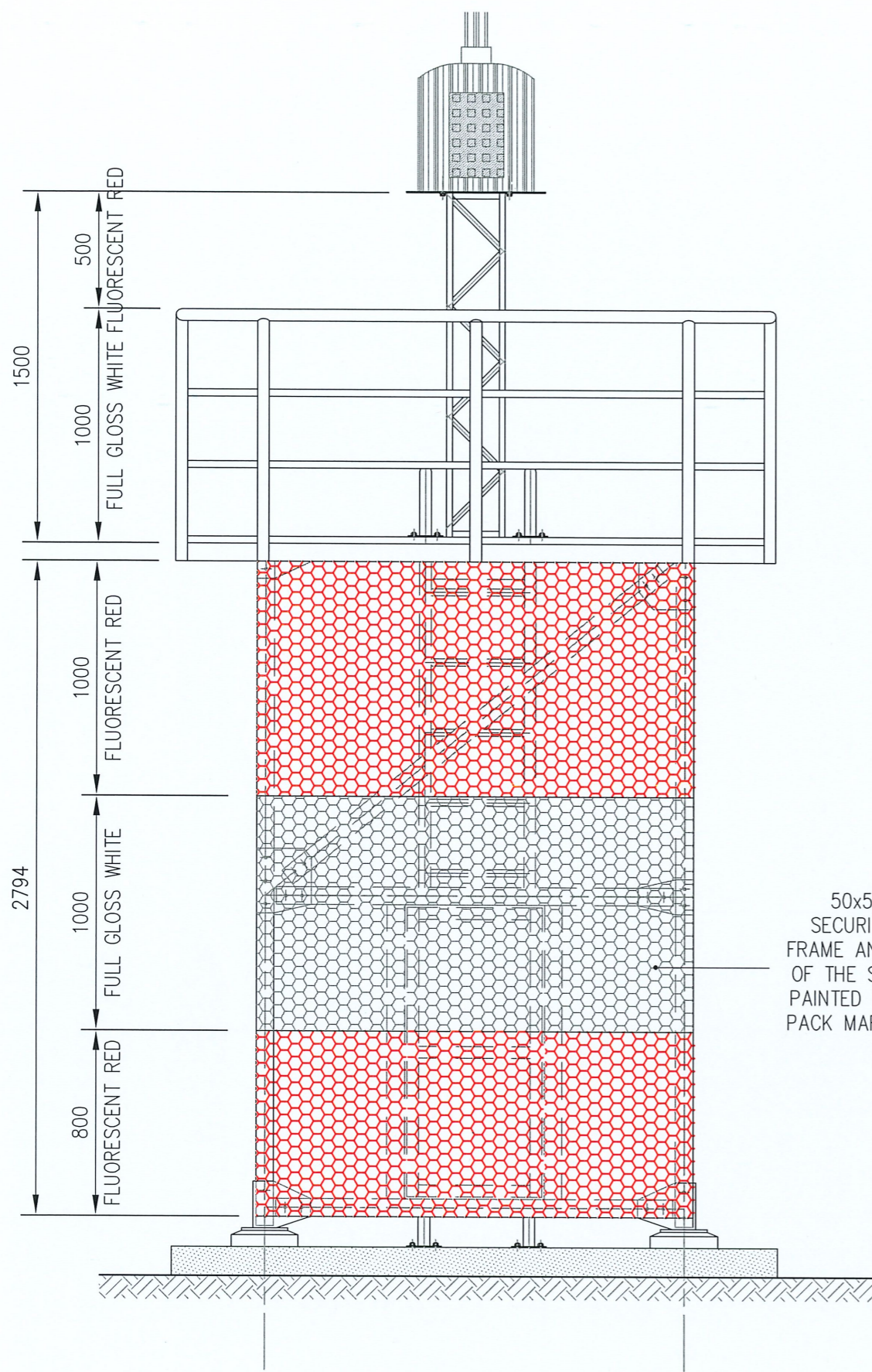

FRONT ELEVATION

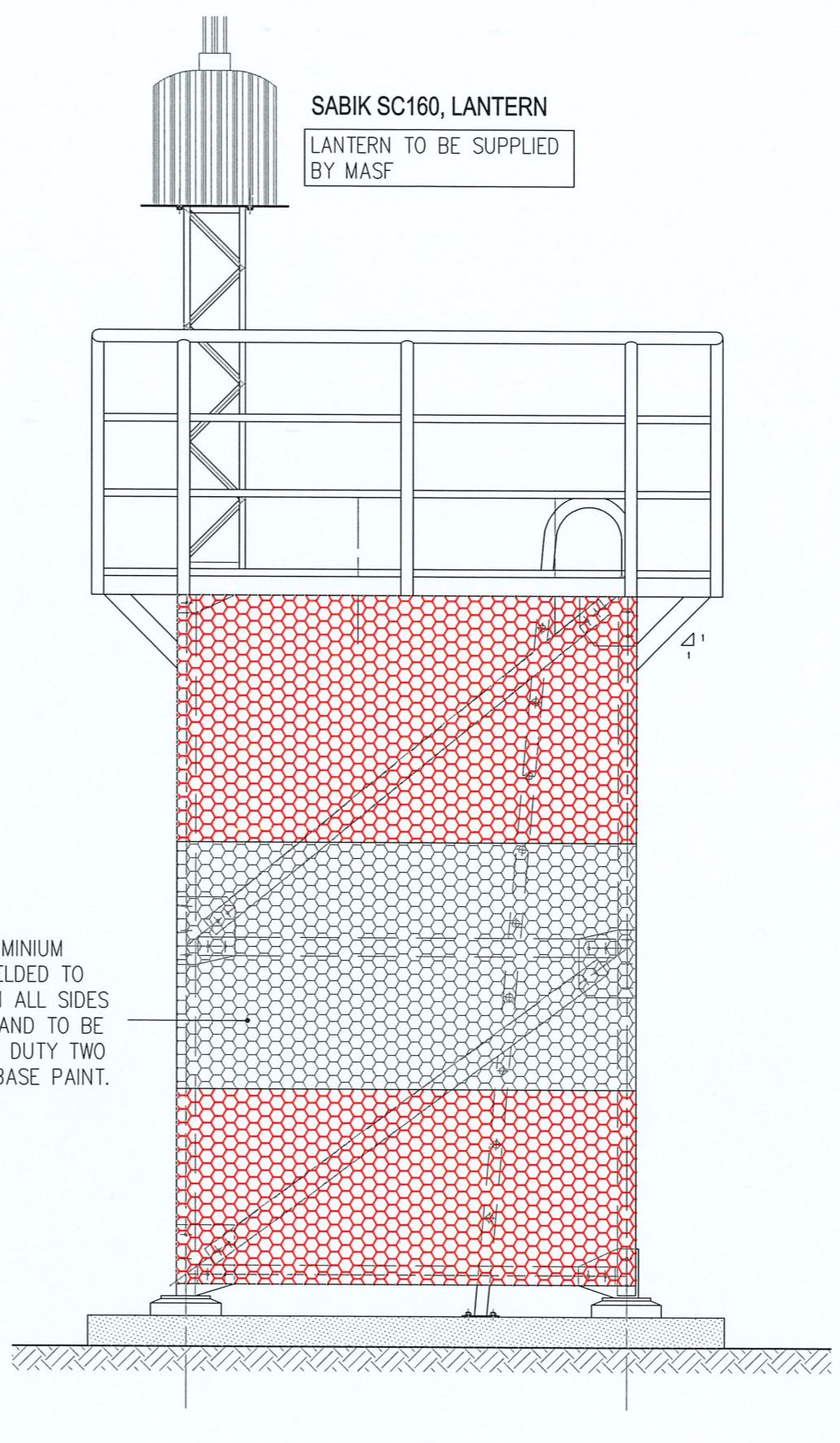

SIDE ELEVATION

50x50x9mm ALUMINIUM SECURITY MESH WELDED TO FRAME AND FIXED ON ALL SIDES OF THE STRUCTURE AND TO BE PAINTED WITH HEAVY DUTY TWO PACK MARINE, ZINC BASE PAINT.

PAINT COLOUR OF THE STRUCTURE

TENDER COPY

11. STEEL REINFORCEMENT TO BE OF GRADE 300 MILD STEEL DEFORMED BARS UNLESS STATED OTHERWISE.
12. SPLICE LOCATIONS OF RE-BARS ARE AS INDICATED. LAP LENGTH WHERE NOT INDICATED TO MINIMUM OF 40 x DIAMETER.
13. PROVIDED SUFFICIENT COVER SUPPORT UNDER RE-BARS TO ENSURE THEY ARE SUPPORTED WELL IN THERE POSITIONS DURING CONCRETE POURING.
14. ALL FASTENING BOLTS TO BE ALUMINUM OR STAINLESS STEEL.

no.	date	details
amendments		
This drawing and all its contents is the property of MPWTMS Structures Section any unauthorized employment or reproduction in full or part is forbidden		
approval		
approval		
client	MARITIME SAFETY AUTHORITY of FIJI LEVEL 4, KADAVU HOUSE	
perm. sec. for PWNST	T. Vakadravuyaca A.Pene	
principle arch/eng	K. M. Zahidul MA	
surveyed	designed	drawn
	MA	MA
checked	date	head subhead
	Sept 23	
		plot date
		18/09/2023
MINISTRY OF PUBLIC WORKS TRANSPORT & METEOROLOGICAL SERVICES		
project PROPOSED LIGHT TOWER FOR MAKOGAI ISLAND		
block/sub proj.		
drawing title FRONT ELEVATION SIDE ELEVATION		
scale As Indicated		
connected drawings		
location no.	file no.	
	building no.	
project no.	sheet no.	amend
STR 1429	03	

A3 ORIGINAL PAPER SIZE

200
150
100
50
40
30
20
10
0

ALL FRAMING MEMBERS TO BE OF
STRUCTURAL GRADE ALUMINIUM

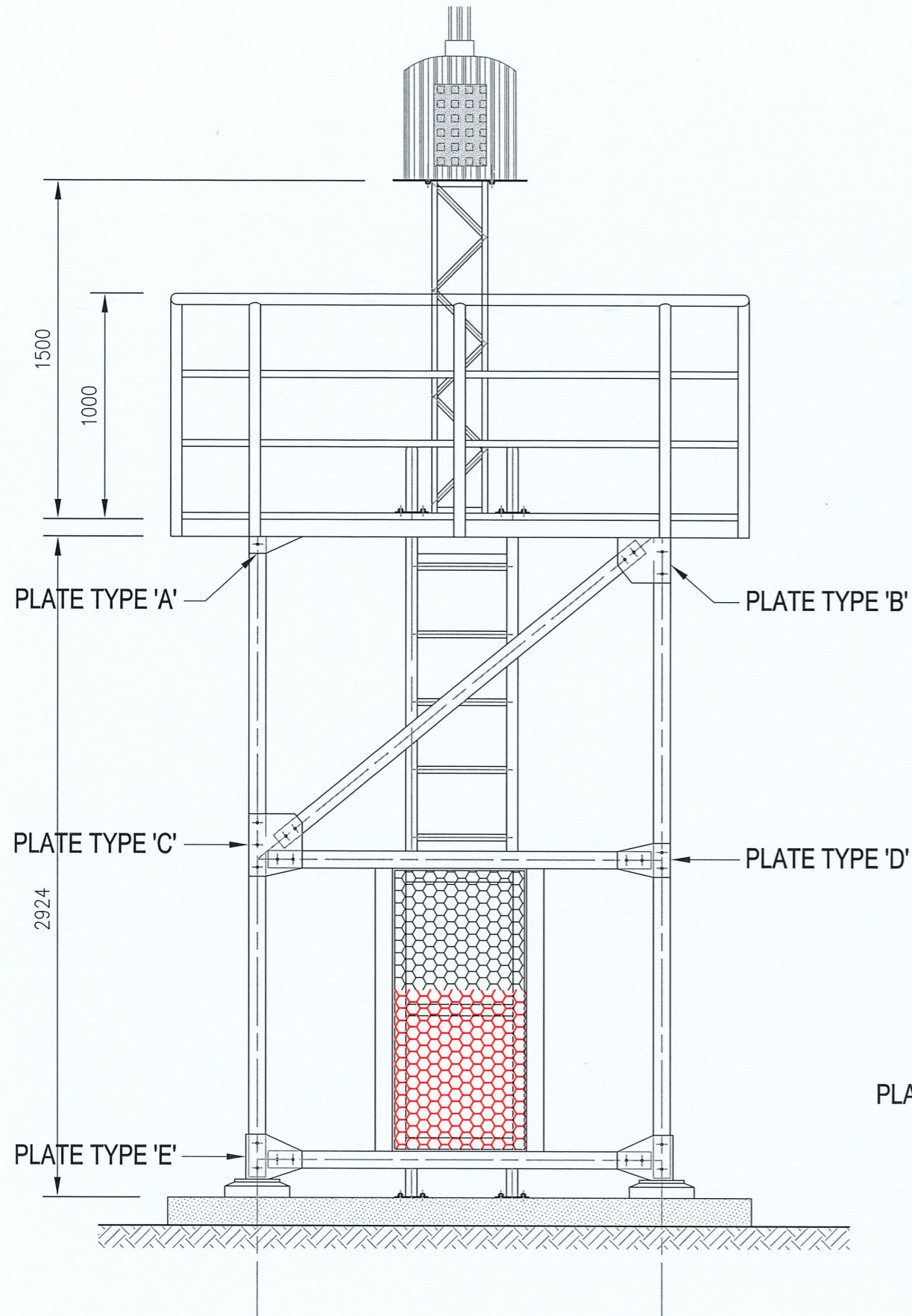

FRONT ELEVATION
SCALE 1:25

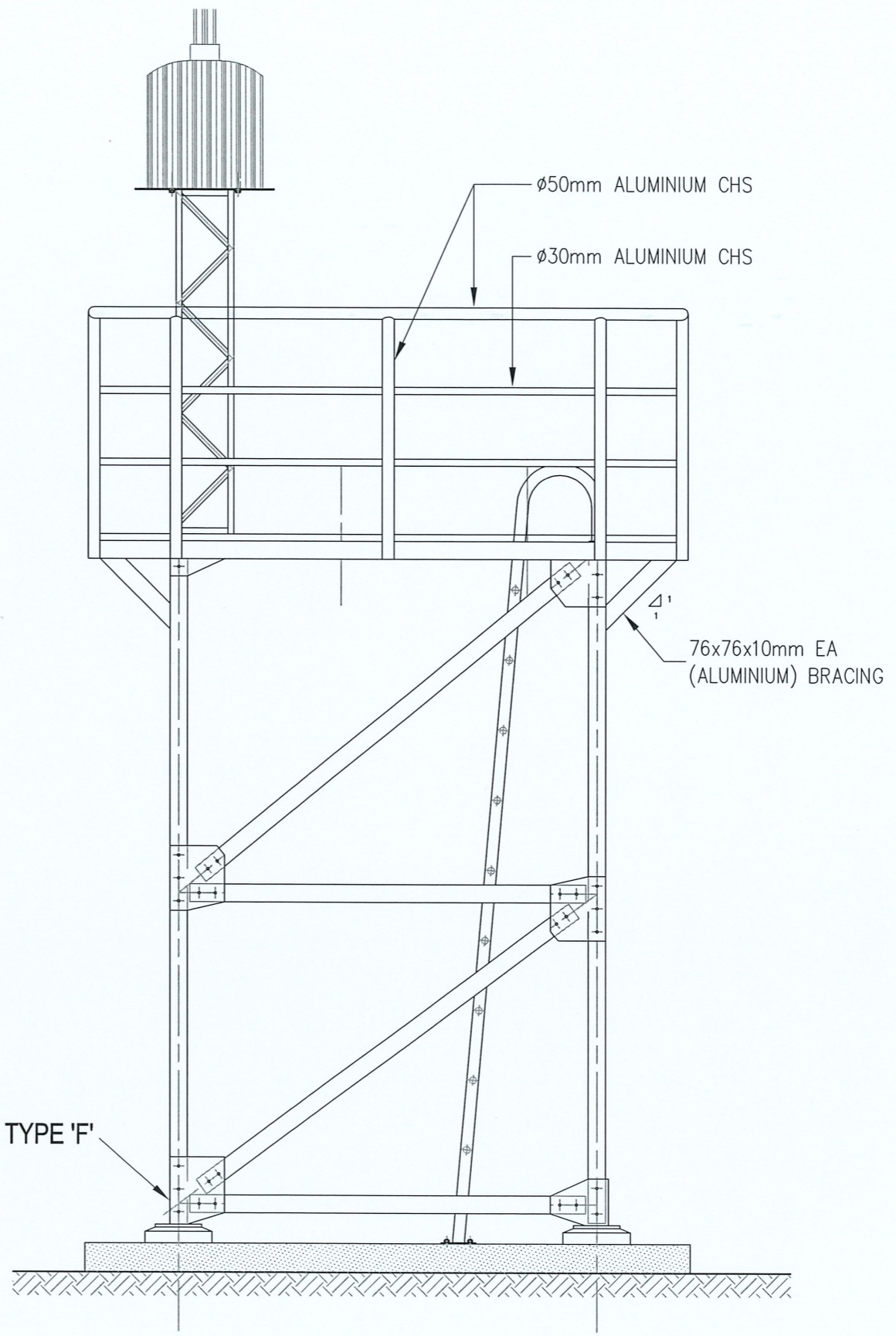

SIDE ELEVATION
SCALE 1:25

TENDER COPY

- NOTES**
15. ALL WELDS TO BE FULL WELDS AND WELDED ALL AROUND.
 16. ALL WELDING WORKS TO ACHIEVE STRUCTURAL PURPOSE QUALITY WELDS. WELDING ELECTRODES USED TO "STRUCTURAL PURPOSE (SP) WELD QUALITY.
 17. BOLTS USED TO BE HIGH TENSILE (AJAX OR SIMILAR) AND ALL BOLTS TO BE FIXED WITH WASHERS & NUTS.
 18. ALL FACES TO BE BOLTED SHALL BE FREE OF PAINT, OIL, RUST, BURR ALL SURFACES TO BE ABRASIVE CLEANED AND COATED WITH ZINC SILICATE.
 19. FOR STEEL CONNECTION, HOLE SIZE TO BE MAXIMUM 2mm LARGER THAN BOLT DIA.

no.	date	details
amendments		
This drawing and all its contents is the property of MPWTMS Structures Section any unauthorized employment or reproduction in full or part is forbidden		
approval		
approval		
client	MARITIME SAFETY AUTHORITY of FIJI LEVEL 4, KADAVU HOUSE	
perm. sec. for PWMTS	section head	
T. Vakdravuyaca	A.Pene	
principle arch/eng	project arch/eng	
K. M. Zahidul	MA	
surveyed	designed	drawn
MA	MA	MA
checked	date	head subhead
	Sept 23	
		plot date
		18/09/2023

MINISTRY OF PUBLIC WORKS TRANSPORT & METEOROLOGICAL SERVICES	
project	
PROPOSED LIGHT TOWER FOR MAKOGAI ISLAND	
block/sub proj.	
drawing title	
FRAMING ELEVATION	
scale	
As Indicated	
connected drawings	

location no.	file no.
building no.	
project no.	sheet no.
STR 1429	04
	amend

A3 ORIGINAL PAPER SIZE

PLOT DATE 12/09/2023

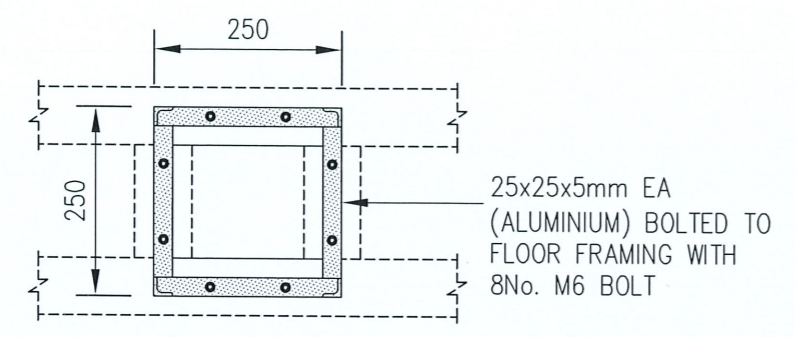

PLAN

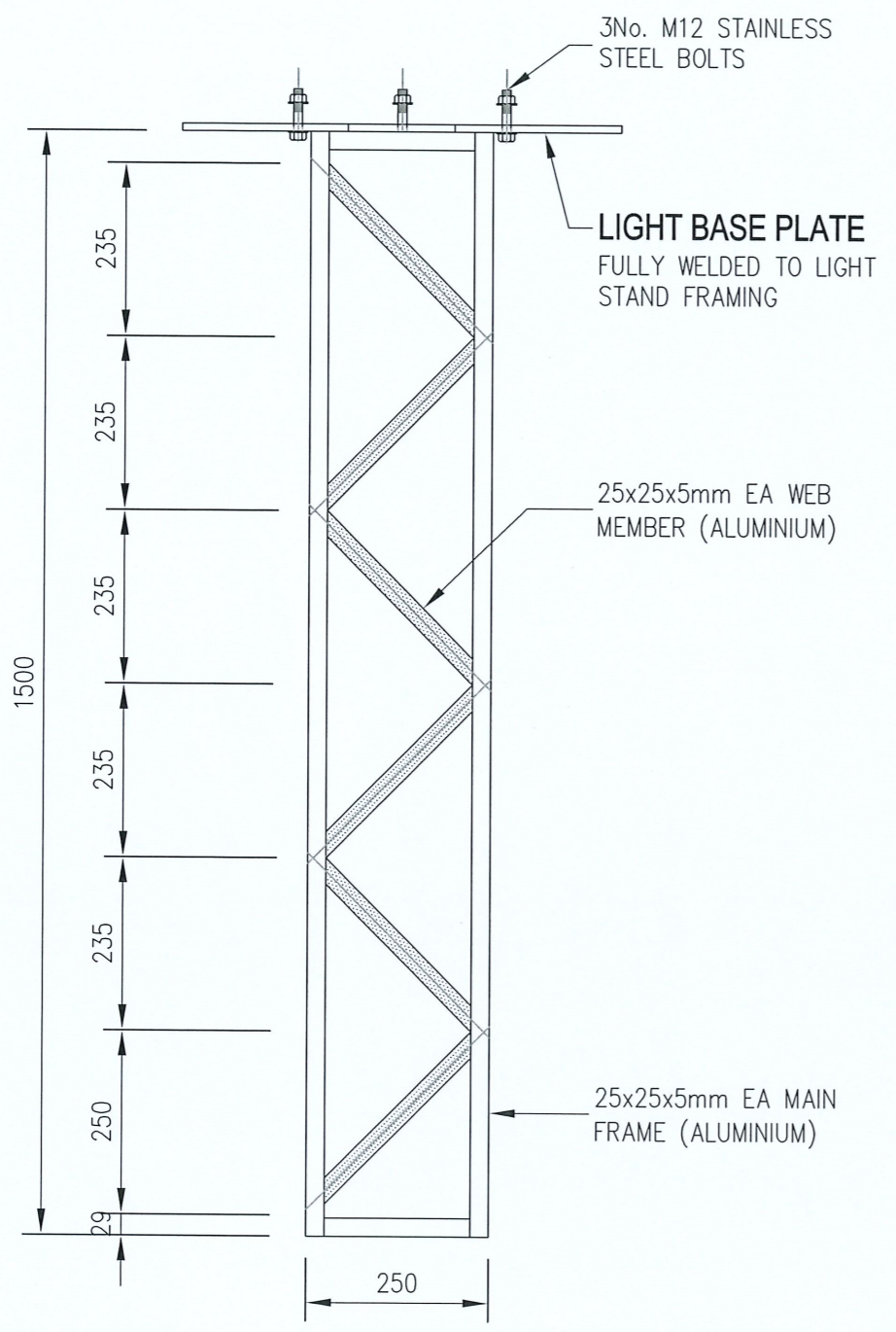

ELEVATION

LIGHT STAND DETAIL
SCALE 1:10

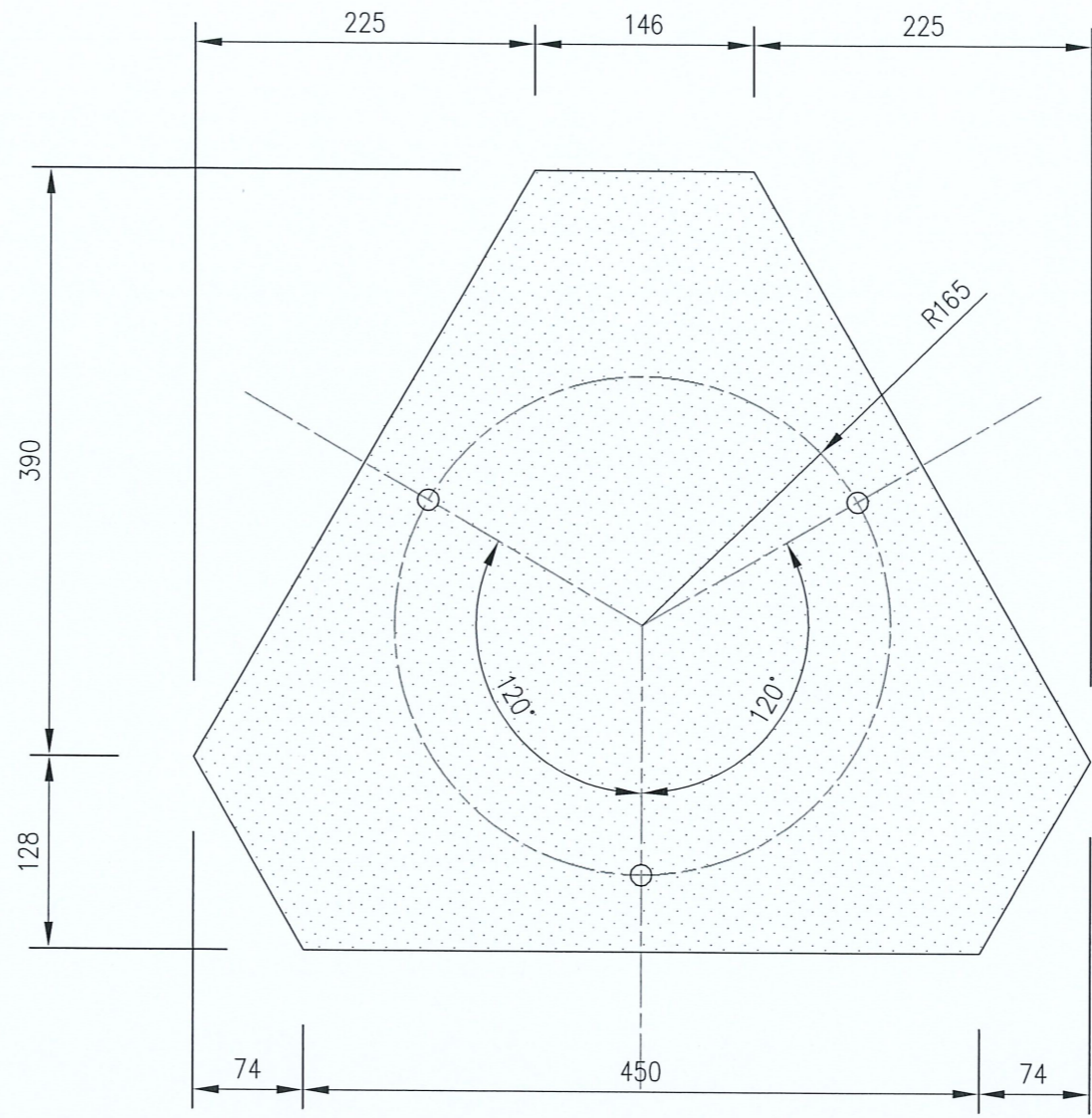

(10mm THICK ALUMINIUM PLATE DRILLED WITH 3No. 14mm HOLES TO SUITE 12mm STAINLESS STEEL BOLTS)

LIGHT BASE PLATE
SCALE 1:5

TENDER COPY

no.	date	details
amendments		
This drawing and all its contents is the property of MPWTMS Structures Section any unauthorized employment or reproduction in full or part is forbidden		
approval		
approval		
client	MARITIME SAFETY AUTHORITY of FIJI LEVEL 4, KADAVU HOUSE	
perm. sec. for PWMS	T. Vakdravuyaca	section head A.Pene
principle archtng	K. M. Zahidul	project archtng MA
surveyed	designed MA	drawn MA
checked	date Sept 23	head subhead plot date 12/09/2023
MINISTRY OF PUBLIC WORKS TRANSPORT & METEOROLOGICAL SERVICES		
project PROPOSED LIGHT TOWER FOR MAKOGAI ISLAND		
block/sub proj.		
drawing title LIGHT STAND DETAIL		
scale As Indicated		
connected drawings		
location no.	building no.	file no.
project no.	sheet no.	amend
STR 1429	05	

A3 ORIGINAL PAPER SIZE

200

150

100

50

40

30

20

10

0

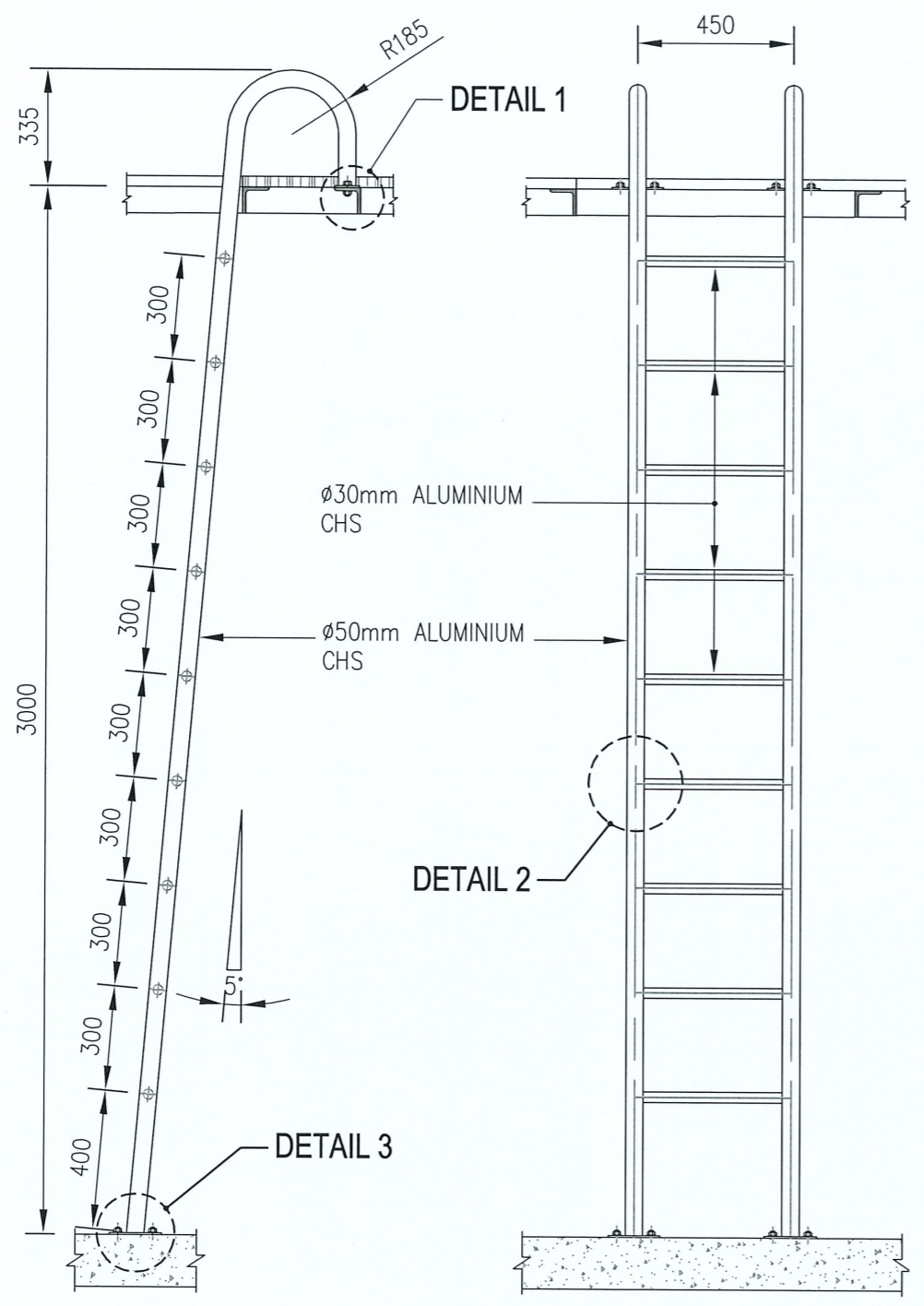

LADDER DETAIL

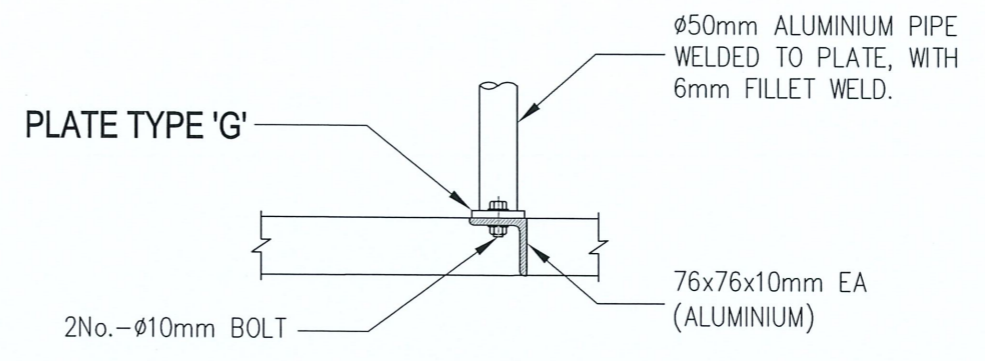

DETAIL 1.
SCALE 1:10.

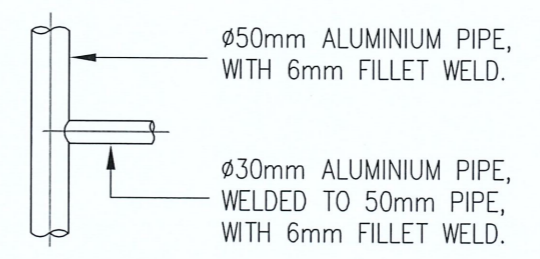

DETAIL 2.
SCALE 1:10.

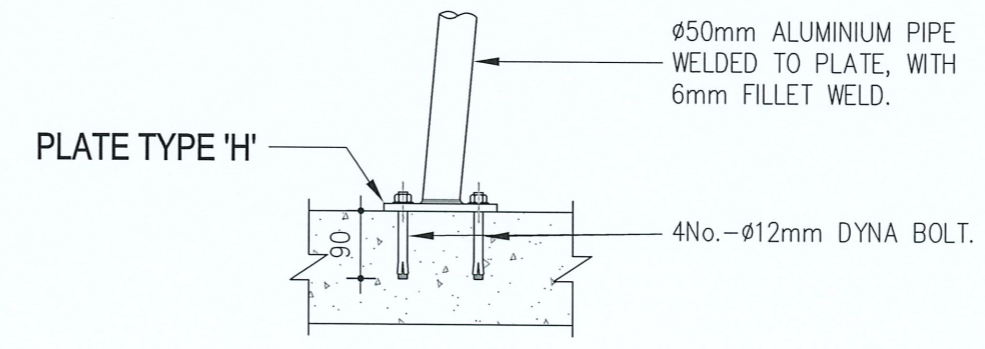

DETAIL 3.
SCALE 1:10.

TENDER COPY

PLOT DATE 12/09/2023

amendments									
This drawing and all its contents is the property of MPWTMS Structures Section any unauthorized employment or reproduction in full or part is forbidden									
approval									
approval									
client									
MARITIME SAFETY AUTHORITY of FIJI LEVEL 4, KADAVU HOUSE									
perm. sec. for PWMTS					section head				
T. Vakdravuyaca					A.Pene				
principle arch/eng					project arch/eng				
K. M. Zahidul					MA				
surveyed		designed		drawn		amend			
MA		MA		MA					
checked		date		head subhead		plot date			
		Sept 23				12/09/2023			
MINISTRY OF PUBLIC WORKS TRANSPORT & METEOROLOGICAL SERVICES									
project									
PROPOSED LIGHT TOWER FOR MAKOGAI ISLAND									
block/sub proj.									
drawing title									
LADDER DETAIL									
scale									
As Indicated									
connected drawings									
location no.									
file no.									
building no.									
project no.		sheet no.							
STR 1429		06							
amend									

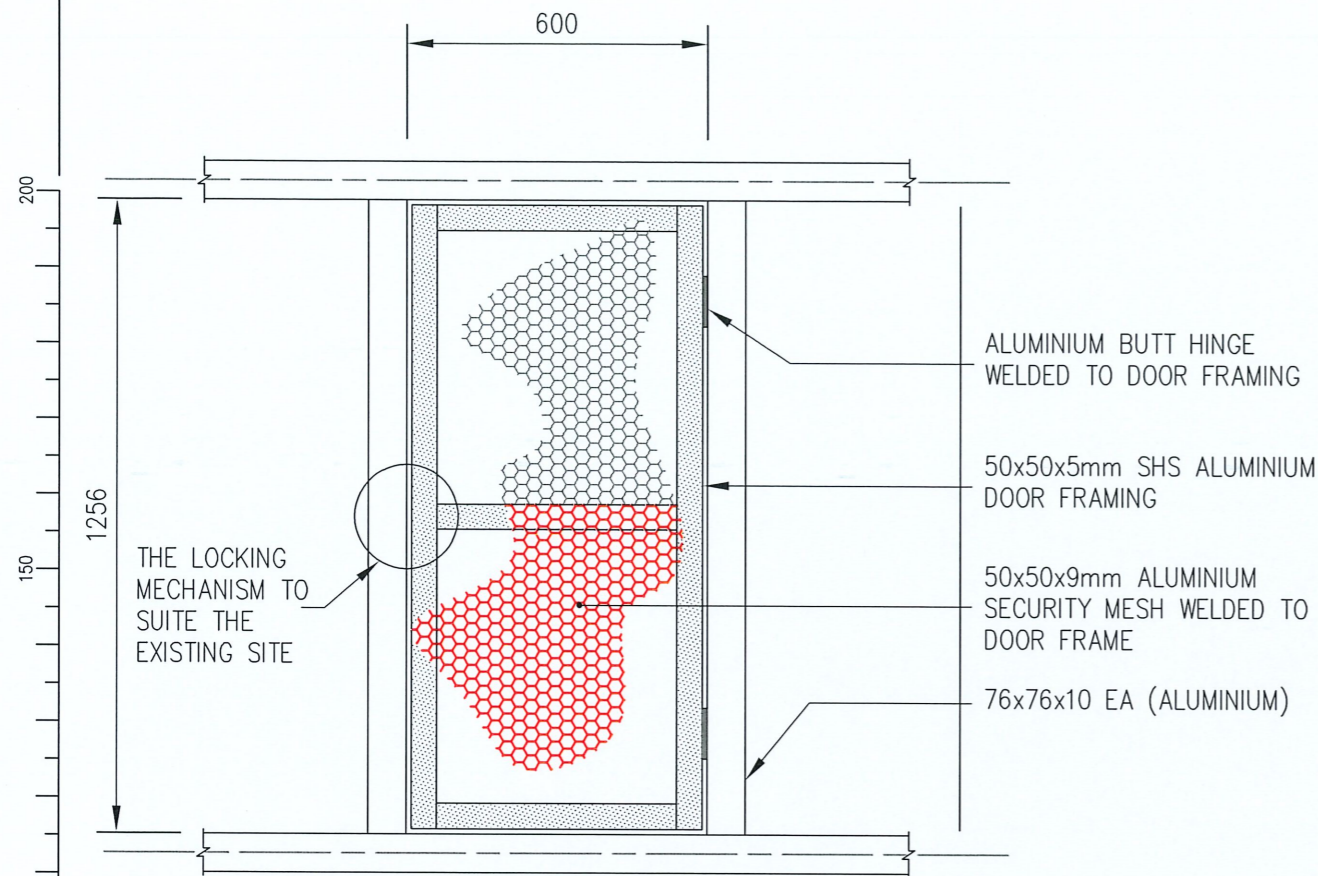

DOOR DETAIL
SCALE 1:15

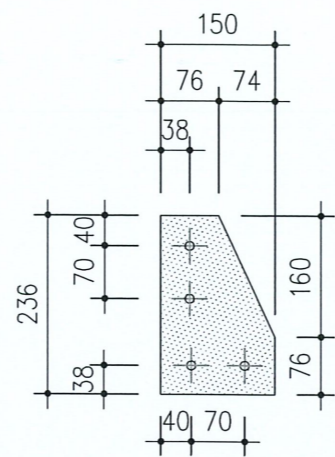

PLATE TYPE 'A'
SCALE 1:10
10mm THICK ALUMINIUM PLATE DRILLED WITH 4No. ϕ 12mm HOLES TO SUIT ϕ 10mm BOLTS

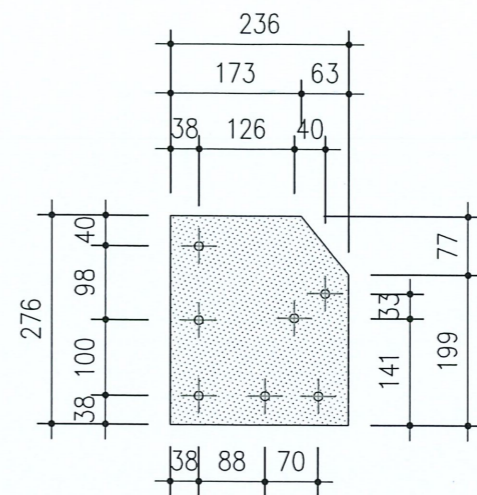

PLATE TYPE 'B'
SCALE 1:10
10mm THICK ALUMINIUM PLATE DRILLED WITH 7No. ϕ 12mm HOLES TO SUIT ϕ 10mm BOLTS

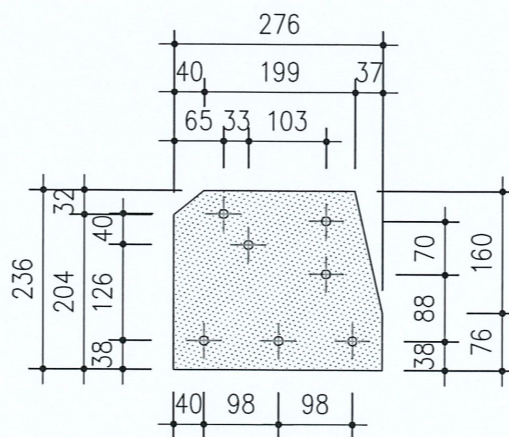

PLATE TYPE 'C'
SCALE 1:10
10mm THICK ALUMINIUM PLATE DRILLED WITH 7No. ϕ 12mm HOLES TO SUIT ϕ 10mm BOLTS

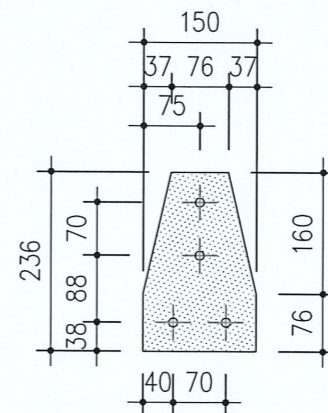

PLATE TYPE 'D'
SCALE 1:10
10mm THICK ALUMINIUM PLATE DRILLED WITH 4No. ϕ 12mm HOLES TO SUIT ϕ 10mm BOLTS

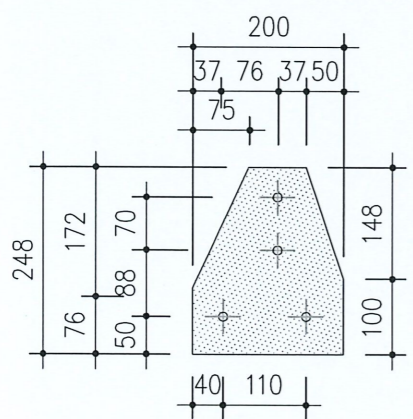

PLATE TYPE 'E'
SCALE 1:10
10mm THICK ALUMINIUM PLATE DRILLED WITH 4No. ϕ 12mm HOLES TO SUIT ϕ 10mm BOLTS

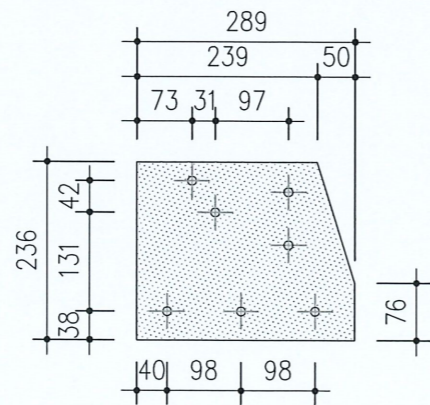

PLATE TYPE 'F'
SCALE 1:10
10mm THICK ALUMINIUM PLATE DRILLED WITH 7No. ϕ 12mm HOLES TO SUIT ϕ 10mm BOLTS

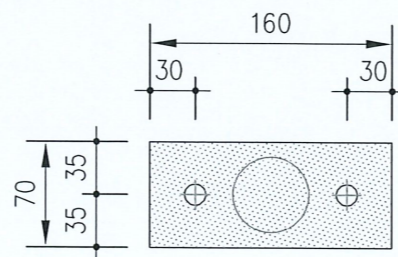

PLATE TYPE 'G'
SCALE 1:5
10mm THICK ALUMINIUM PLATE DRILLED WITH 2No. ϕ 12mm HOLES TO SUIT ϕ 10mm BOLTS

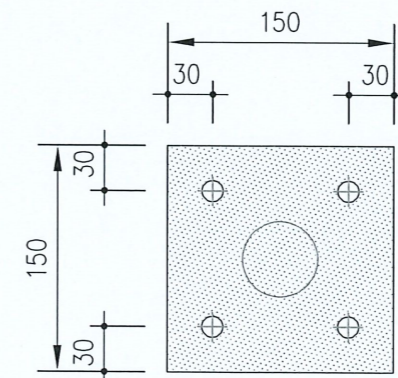

PLATE TYPE 'H'
SCALE 1:5
10mm THICK ALUMINIUM PLATE DRILLED WITH 4No. ϕ 12mm HOLES TO SUIT ϕ 10mm BOLTS

TENDER COPY

NOTES			
no.	date	details	
amendments			
This drawing and all its contents is the property of MPWTMS Structures Section any unauthorized employment or reproduction in full or part is forbidden			
approval			
approval			
Client			
MARITIME SAFETY AUTHORITY of FIJI LEVEL 4, KADAVU HOUSE			
perm. sec. for PWTMS	section head		
T. Vakadravuyaca	A.Pene		
principle architect	project architect		
K. M. Zahidul	MA		
surveyed	designed	drawn	amend
MA	MA	MA	
checked	date	head subhead	plot date
	Sept 23		18/09/2023
MINISTRY OF PUBLIC WORKS TRANSPORT & METEOROLOGICAL SERVICES			
project			
PROPOSED LIGHT TOWER FOR MAKOGAI ISLAND			
block/sub proj.			
drawing title			
DOOR DETAIL & PLATE DETAIL			
scale			
As Indicated			
connected drawings			
location no.	building no.		file no.
project no.	sheet no.		amend
STR 1429	07		

A3 ORIGINAL PAPER SIZE